

Proposed Additional Play Equipment at Bury Road.

A request from local residents at Clopton Green, represented by Mr K Grimes who undertakes the inspections of play equipment at the Bury Road Pocket Park was received last year to look into the purchase of additional play equipment for older children (8 plus) to use.

In October 2020 the Estates Committee considered the purchase of an additional piece of play equipment for children between 8 and 12 at the Bury Road Pocket Park (**Minute 19.10.12 refers**) and agreed the proposal should be tabled at the next meeting of the Parish Council for approval. The Parish Council meeting in October authorised the Clerk to seek match funding for the cost of any play equipment.

Progress on seeking match funding the play equipment has been delayed as the Clerk has to date been unable to obtain a third quote with specification on the cost of supplying the type of multi play equipment the Estates Committee had identified, of a nature which the parents and children at Bury Road had requested.

By October 2019, only one company had responded to enquiries, Playforce, which undertook a site visit on 29th July 2019, and suggested the multi-play unit indicated below:







The equipment provides a climbing wall, slide and clamber equipment and the company who provided the quote (attached as Appendix A to this report) confirmed that it would be suitable for the age range 8 plus, identified by Mr Grimes and parents local to the pocket park. Mr Grimes has indicated that this proposal had the support of local parents.

The Council's Financial Regulations (last adopted May 2020, **Min.19.09.06.2.7** refers) make provision at 11.1.h that where the council is

"to enter into a contract of less than £25,000 in value for the supply of goods or materials or for the execution of works or specialist services other than such goods, materials, works or specialist services as are excepted as set out in paragraph (a), the Clerk or RFO shall obtain 3 quotations (priced descriptions of the proposed supply);

The Clerk contacted three further playpark providers for full quotations in order to comply with the Council's financial regulations. Full quotes and specifications are attached as Appendix A to this report and a summary set out in the table below.

Play provider	Equipment	Cost
Playforce (Appendix 1)	Multiplay Unit (full quote and spec rec'd) 	1. Jungletops Single Tower Featuring: • 1x 1.4m Tower • 1x 1.4m Rock Climb • 1x 1.4m Slide • 1x Tangle Tree Climb 1.4m PTTT017-A-PT £ 6,039.20 2. 8m2 Safer Impact Grass Tiles - API advise 2m CFH when installed on to well kept grass PSUR116-A-NA £ 259.20 Total £ 6,298.40
Sovereign (Appendix 2)	Calypso with slide 	£16,544.84
Eibe Play (Appendix 3)	Bain Unit 	<ul style="list-style-type: none"> • 1.45m Stainless Steel Slide • Ramp Assent • Banister Slide • Metal post feet £17,383.87 + VAT
Eibe Play (Appendix 4)	Alvier Unit 	<ul style="list-style-type: none"> • 1.45m Stainless Steel Broad Slide • 0.95cm GRFP Slide • Monkey Bars • Metal post feet £20,233.08 + VAT

At 31st March 2020, Earmarked funds for playground replacement stood at £4000. A further £1500 was allocated in the budget for 2020 – 2021.

Applications to district and county councillors for locality funding, if approved, could further reduce the net cost of the proposed replacement option.

At its meeting in June 2020 the Estates Committee resolved to recommend to the Parish Council that the proposal and quote submitted by Playforce, at a cost of £ 6,298.40 (**Min.20.06.09 refers**) be approved. The meeting also asked the clerk to look for any grants that might off-set the total cost.

The Estates Committee had also previously asked the clerk to identify a replacement option for the entrance gate to the Bury Road Pocket park (**Mins. 20.03.7.5.4 and 20.06.08.6 refer**). Options identified are listed below and images attached as Appendix B.

Supplier	Item	Cost	Notes
Playforce	1.2m premier sprung self closing gate	£783.60 + VAT	Fitted. To dig out and remove existing gate £175 + VAT
Easygate	1.2m high self closing gate	£690 plus VAT	Not Fitted Carriage £90 + VAT
MGC	1.2m high self closing gate	£1050 plus VAT	Not Fitted Carriage £80 + VAT

Fitting of the gate by Playforce could be completed at the same time as the installation of the new equipment.

Earmarked reserves for Playground and Teen Project maintenance at 1st April 2020 were £2765.27.

Recommendation:

- 1. The Parish Council authorise the cost of the play equipment identified at Appendix 2 to the report based on the quote provided by Playforce, at a cost of £6,298.40 plus VAT, to be funded from £5,500 in earmarked reserves, the balance of to be funded from general reserves (£2058.08) and the Clerk be delegated to instruct Playforce for the work.**
- 2. The Parish Council authorise the cost of a replacement sprung self-closing gate at a cost of £783.60 plus VAT, and further authorise the cost for Playforce to dig out and remove the existing gate at £175 plus VAT. The Parish Council delegate the Clerk to instruct Playforce for the work.**
- 3. The clerk continue to search for sources of funding to off-set the cost of the play equipment authorised at 1 above.**

Relevant Minutes:

20.06.09

19.10.15

EC.19.10.12

19.06.9.4

19.04.8.4

19.02.8.4

18.12.8.3

1 Pegasus Way, Bowerhill Ind. Est.
Melksham, Wiltshire, SN12 6TR
e: sales@playforce.co.uk t: 01225 792660
f: 01225 792080 www.playforce.co.uk

Hilary Workman
Wickhambrook Parish Council
123 York Road
Bury St Edmunds
IP33 3EG

29 August 2019

Ref: 126557/JH

Dear Hilary,

Re: Bury Road Play Area

Thank you very much for your time to discuss the potential play area project at Bury Road. Following our meeting I am very pleased to provide you with a quotation for the supply and installation of our **Jungletops Single Tower**, adding an exciting and challenging play experience to the existing area.

The quotation includes the supply and installation of the new unit along **Safer Impact Grass Tiles** around the high wear areas, conforming with both EN1176 & EN1177 safety standards.

Please note: as school funds are always precious, we have been encouraged by the Association of Play Industries to draw your attention to item 5 ('Financial Security') of the 'APi Top Tips' document, which can be found on our website at www.playforce.co.uk/important-info.

I hope you have found the above information useful and we are able to help achieve the best play value from your outdoor space. Should you wish to use our installation as a project for the children, our installation teams are very happy to help facilitate this and answer any questions the children may have.

I will give you a call shortly to discuss how you may wish to proceed. If you would like to call me in the meantime, please do so on 07540 758555.

With kindest regards,

John Hambrook
Sales Manager

Tel: 07540 758555

Email: John.Hambrook@playforce.co.uk

Web: www.playforce.co.uk

Wickhambrook Parish Council - Bury Road
Playforce Quotation Reference: 126557

Enclosed for you

- ✓ Your Quote
- ✓ Scale Plan
- ✓ Play Equipment Specification Details

Wickhambrook Parish Council - Bury Road
Playforce Quotation Reference: 126557

Supply, Delivery and Installation

- | | | |
|--|---|----------|
| 1. Jungletops Single Tower | £ | 6,039.20 |
| Featuring: | | |
| • 1x 1.4m Tower | | |
| • 1x 1.4m Rock Climb | | |
| • 1x 1.4m Slide | | |
| • 1x Tangle Tree Climb 1.4m | | |
| PTTT017-A-PT | | |
| 2. 8m ² Safer Impact Grass Tiles - API advise 2m CFH when installed on to well kept grass | £ | 259.20 |
| PSUR116-A-NA | | |

Total £ **6,298.40**

Please note that all prices are subject to VAT, and quotations are valid for a period of 3 months from the date stated above.

Flexible Payment

At Playforce, we can provide all of our customers with flexible payment options with payments spread a number of years. This allows you to enjoy your full and dream project immediately, whilst paying for the project as if it had been phased over several years.

For more information call 07540 758555

Playground Inspections

The British Standards for Playground Equipment and Surfacing, BSEN 1176 advises that all playground installations should be inspected by a competent person, and that the schedule should include routine daily/weekly inspections, operational and annual inspections.

We can take the hassle out of organising these for you with our Playforce Care inspection package. This covers the main annual inspection, three operational inspections and also includes on-site training for a member of your staff in undertaking weekly and monthly routine inspections. There are also discounts available for multiple sites in the same locality.

If you would like to include this inspection package, please indicate this when placing your order.

- | | | |
|---|---|---------------|
| * Annual Inspection Package – includes 1 x independent RPII-accredited annual inspection and report, 3 x quarterly operational inspections and on-site training for a member of your team | £ | 525.00 |
| Total | £ | 525.00 |

Please note that all prices are subject to VAT, and quotations are valid for a period of 3 months from the date stated above.

29 August 2019

Wickhambrook Parish Council - Bury Road

Playforce Quotation Reference: 126557

The Playforce Design & Build and Playforce Sale of Goods terms and conditions available at www.playforce.co.uk/important-info ("Terms and Conditions") shall apply to any orders that you may place with us and that order is made subject to those Terms and Conditions. By placing an order with us for goods and/ or services, you confirm that you have read and agree to the Terms and Conditions. In particular, please ensure that you read and agree to clause 12 of those Terms and Conditions which contains limits on our liability. Please note, all deposits are non-refundable.

All plans, quotations and correspondence between Playforce and the addressee are to remain strictly confidential between those parties only. Our customers value our uniquely creative designs, which are one of the qualities that set us apart from the competition and aid us in achieving best value!

All of our play equipment and safer surfacing conforms to the British and European Playground Safety Standards BS EN 1176 and 1177.

Please note that line markings and wetpour surfacing are weather dependent and as a result they may not be completed at the same time as the equipment installation. In this event, we may invoice the individual elements separately. When this is done, we will expect payment of each separate invoice in accordance with our terms and conditions. Wetpour surfacing colours can be affected by UV light at the time of installation. This will only be a temporary colour change, before the surfacing returns to its intended vibrant colour.

Tarmac surface skims are installed onto existing surfaces with the understanding that Playforce Ltd will not be held responsible for future repairs resulting from weed growth damaging the tarmac surface.

Playforce recommends the installation of kerb edging when installing wetpour surfacing onto tarmac / concrete and other hard surfaces. This type of edging detail provides a suitably firm fixing point for the surface and protects the surrounding hard surface from future cracking or failure. Chased edges can be provided but Playforce does not accept responsibility for any future repairs to the tarmac / concrete / hard surface or wetpour resulting from the expansion and contraction forces exerted by the surfacing.

Softbond mulch is frequently specified for installation onto existing grassed areas. Whilst we take care to ensure the suitability of the ground conditions at the time of specifying the product, there can be occasions when the ground beneath the softbond mulch, over a period of time, can move, causing the softbond mulch to sink. For this reason, Playforce advises the laying of an MOT Type 1 base before laying softbond mulch. Playforce therefore does not cover the costs of repairing these areas under warranty should the MOT option not be chosen.

Please note that we are unable to offer a warranty on wetpour repairs or surface skims with regards to the bond to an existing edge or existing surfaces. We would not recommend patch repairs, especially along edges as a suitable long-term solution.

The customer / client is reminded that it is their responsibility to ensure grassed areas are regularly cut and maintained to a height not exceeding 50mm, prior to the installation of any surfacing that may have been ordered. Failure to do so will incur costs for delays; any aborted visits or any other cost interrupting planned work.

We recommend that all existing court markings are removed before laying new line markings. Please note that removal of line markings come at an additional cost and this is not included with new line markings unless included specifically in your quotation. Failure to remove line markings before laying new ones will mean we are unable to offer a warranty on the new thermoplastics. We are also unable to offer a warranty for laying line markings over excavated or joined tarmac.

To place your order, either send an e-mail to John.Hambrook@playforce.co.uk, stating your quote reference number (as on the top of this quote) and the value that you approve, or sign and date below and fax, email or post the confirmation back to us.

I agree and accept the above quotation from Playforce Ltd reference number 126557 dated 29 August 2019 to the value of £_____.

Signature:

Print:

Position:

29 August 2019

Wickhambrook Parish Council - Bury Road

New Multiplay Unit



Equipment & Surfacing
1. Jungletops Single Tower (1.4m)
2. 8m² of Safer Impact Grass Tiles



All Playforce products comply with the British and European standards EN1176 for Playground Equipment and EN1177 for Impact absorbing Playground Surfacing.

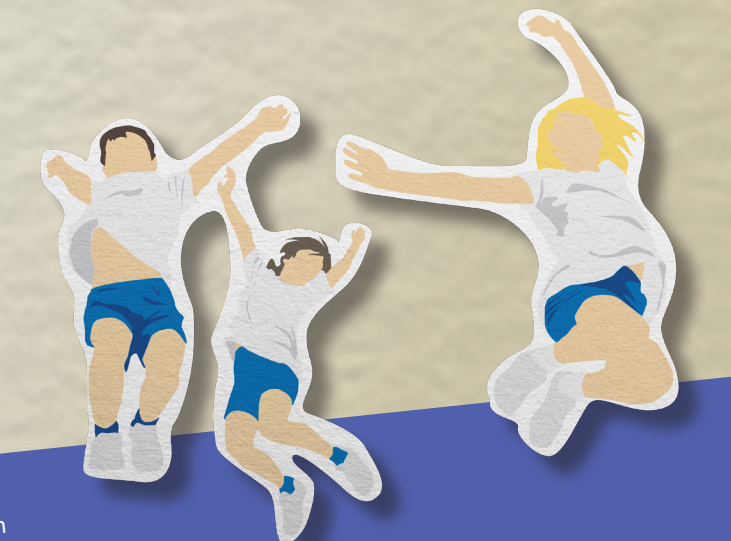
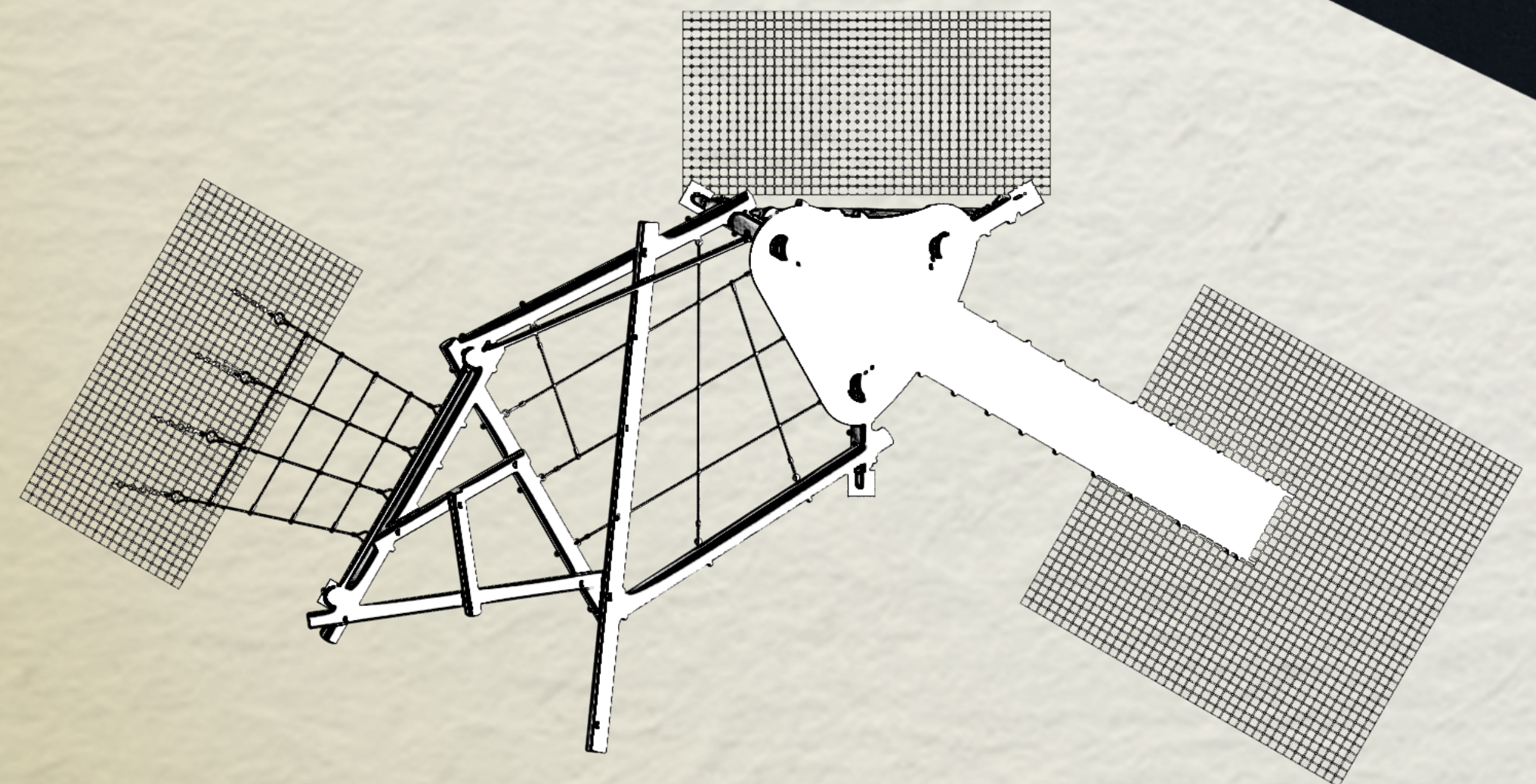



SOVEREIGN
Bringing imagination into play



» Wickhambrook
Parish Council



Introduction



Our Ref: S4/44328

19th February 2020

Wickhambrook Parish Council
123 York Road
Bury St Edmunds
IP33 3EG
Suffolk

Dear Sir/Madam,

Thank you very much for the opportunity to develop your outdoor environment.

I sincerely hope our quotation is of interest to you. Should you need us to make any alterations to the content of the design, we are very flexible and always willing to help.

Your quotation has been fully itemised to make the selection process as easy as possible and includes everything you need for your project. You can be reassured that we won't surprise you with any nasty hidden costs.

All of our equipment and surfacing is designed, manufactured and installed to current British Standards 1176 and 1177. We are approved members of CHAS and Construction Line, and our timber is FSC certified. We have many further accreditations which are detailed within this pack along with examples of our work and extensive warranties.

Once again I would like to thank you for this opportunity to present my proposals and genuinely hope that they will be of interest to you.

Should you have any queries or questions at any time please feel free to contact me directly, my mobile and email can be found below.

I look forward to hearing from you.

Assuring you of our best attention,

On behalf of Sovereign

A handwritten signature in black ink, which appears to read 'Tony Robinson'. The signature is written in a cursive style.

Tony Robinson

Area Sales Manager

Mob: 07787 157685

Email: tony@sovereignplay.com

Area One



> Calypso with Slide

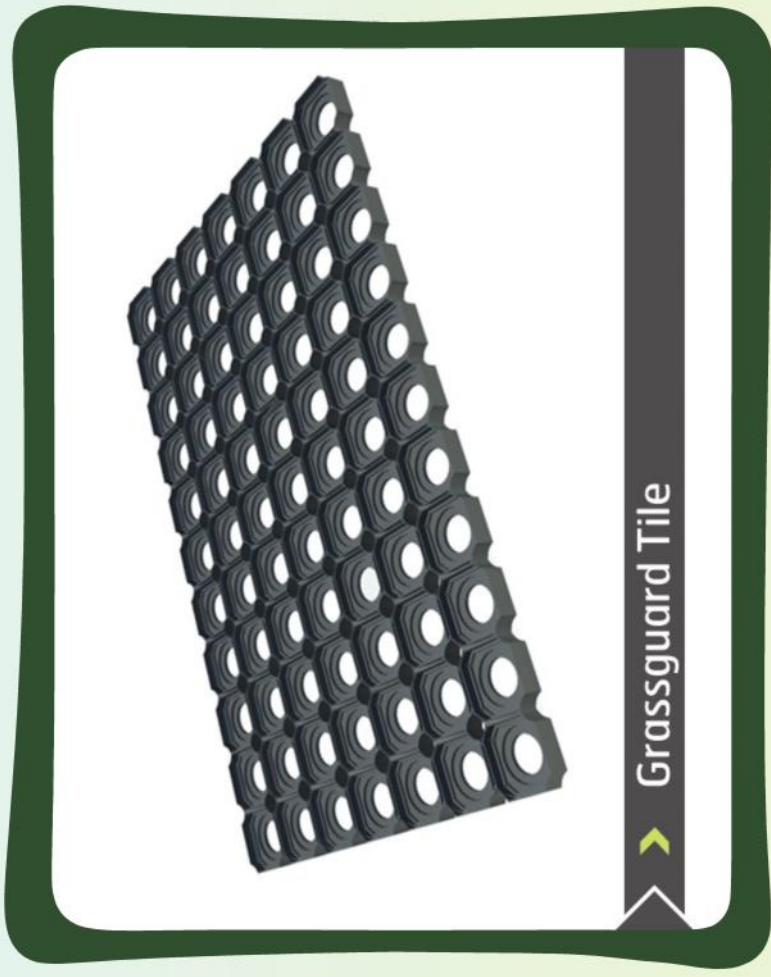

> Grassguard Tile



Wickhambrook Parish Council

Images shown are for representational purposes, products may vary. T: 01702 291129 - www.sovereignplayequipment.co.uk

Ref: 44328
Date: 19-02-2020
Scale: N/A
Designer: LW
Area Manager: Tony Robinson
www.sovereignplayequipment.co.uk



SOVEREIGN
Bringing imagination into play



Qty	Ref	Equipment	Price
1	A	Calypso with Slide With Installation Into Grass	£12,732.10
Sub Total			£12,732.10
Qty	Ref	Surfacing	Price
70	B	Grassguard Tile (1.5 x 1m Tile) Installation	£2,304.74
Sub Total			£2,304.74
Qty	Ref	Removals	Price
1	R1	Optional subsidised removal of spoil and/or waste material off site. (One charge applicable per order) Removal	£200.00
Sub Total			£200.00
Qty	Ref	Welfare & Security	Price
1	WF1	Provide heras type fencing (as recommended by the Health & Safety Executive) and signage for the duration of the contract Other items/services	£366.00
1	WF2	Provide security container for overnight storage for the duration of the contract Other items/services	£618.00
1	WF3	Water Bowser required on site for the duration of the contract Other items/services	£324.00
Sub Total			£1,308.00
Project Total:			£16,544.84
Sovereign Spread Payment plan:			£6,436.13

Qty	Ref	You May Also Require (Prices below are NOT included within total)	Price
1	ROSPA	Independent Post Installation Inspection (recommended additional option) Other items/services	£474.00

Subject to full technical site survey. Item location to be confirmed and therefore prices are subject to change. Prices are based on good access and level grass for installation.

Sovereign Spread Payment Plan: First payment required after delivery/installation, with two following payments after 12 and 24 months. Subject to Status. Terms and conditions apply.

All prices are valid for 30 days, include delivery, exclude VAT and may be subject to a technical pre-installation site survey. E and OE, subject to our Terms and Conditions.



SOVEREIGN
Bringing imagination into play

Product Description

Sovereign's grass tile surfacing is ideal for grass areas that require protection against erosion from foot traffic, and is perfect for both low and high level adventurous play equipment. Tested to BS EN 1177 up to 3000mm respectively onto well kept grass.

Grass Tiles

Product Code **GG / V4 / D4**



Technical Details

Free Height Of Fall <3000mm

Length **1500mm**
Width **1000mm**
Height **23mm**

Installation

The matting is laid directly onto well-drained grass with a mesh underlay without the need for any expensive base works. When the area is fully established, it provides a firm bond to the ground and excellent grass reinforcement properties.

Maintenance

The open cellular construction of the matting allows grass to grow up through it, which can then be cut with a conventional mower. There are no specific maintenance requirements.



Sovereign Design Play Systems Ltd | Registered office: 40 Towerfield Road, Shoeburyness, Southend-On-Sea, Essex, SS3 9QT | Reg No: 5024016 - Registered in England

» Additional Information



Pre Installation Surveys

If you are having old equipment / surfacing removed from the area of installation or groundwork's undertaken by any party other than Sovereign, we would recommend a pre-installation survey to confirm the area has been prepared correctly prior to our works commencing. The cost for the pre-installation survey is £149.00 plus VAT.

Should you not opt for a pre-installation survey, and works are not completed as required this may lead to either a suspension of the installation and an abortive visit charge, or alternatively we may be able to complete the preparation and charge accordingly.

Underground Services

All due care will be taken to locate underground services prior to excavation, however no responsibility can be accepted if any unknown or incorrectly sited services are damaged. Where possible, we ask you provide us with drawings or plans for services.

Supply Only / Installation by a Third Party

Sovereign cannot accept duty of care for equipment sold as supply only and installed by a third party.

Planning Permission / Building Regulations

It is your responsibility to obtain any necessary approval and we strongly recommend you obtain appropriate advice from your local authority before proceeding, as requirements can vary.

Design changes due to planning permission and building regulations requirements may incur additional costs. You will be responsible to pay any fees relating to planning applications, building regulation applications, local authority and survey fees.



» Payment Terms



Payment Terms Explained

The prices within our quotation are based on a 20% deposit, and the remaining 80% balance due within 30 days upon completion of the works.

Sovereign reserves the right to invoice at intervals during the installation once agreed stages have been completed.

Additional Notes

All prices are valid for 30 days, exclude VAT and maybe subject to a technique pre-installation site survey.

Although every care will be taken, our quotation does not include for damages that may occur over the access route.

Unless stated otherwise, levelling of the proposed installation area is not included with our quotation and new surfacing will follow the undulations of the ground.

Enclosed are our terms and conditions.

Should you have any questions, queries or would like any further information please do not hesitate to contact our office.

Sovereign Spread Payment Plan

Should you choose to spread the costs of the project through our Spread Payment Plan then this could not be simpler. These terms are based on 3 singular payments. One payment after delivery/installation one payment in 12 months' time, and your last payment in 24 months' time. Please note that the minimum order amount is £3,000 (*£1,000 per payment - Subject to Status*)



SOVEREIGN

Bringing imagination into play



» Why make them wait?

Did you know you can order your new equipment today and pay with our Spread Payment Plan?



The biggest constraint of developing outdoor areas is budget, particularly with the reduction in devolved formula capital. Our easy Spread Payment Plan allows you to order today and pay over three simple spread payments while your children benefit from additional years of enjoyment and physical development.

Benefits include:

- Allows the opportunity to continue to fund raise, while having the use and benefit of the new equipment
- Buy at today's prices, saving you money in the long term
- Pay over three financial years; one payment after delivery/installation, one payment 12 months' later and your last payment 24 months' after delivery/installation
- Simple, stress free process with full support

In short, if you need to update, extend or upgrade your current outdoor facilities, whatever it may be, our Spread Payment Plan could well be the solution to making your dreams a reality.

Call today to discuss how our Spread Payment Plan can help you!

Please Note: Terms and Conditions apply - Credit checks may be required - Minimum £3000.00 spend - Not available on special offer prices.



Tel: 01702 291129 Web: sovereignplayequipment.co.uk

Email: info@sovereignplay.com

» Choosing the Right Company



Choosing the right company to carry out work in your school is not easy; especially with so many companies all seeming to offer 'similar' products and services. This simple form will help you ask the right questions, and ensure your school is getting the best value it can. All the questions below are ones you should be asking before making your final decision. All will affect quality, service life and most importantly safety. Before making your decision solely on price, consider why the prices are what they are, and are you obtaining quotes from established play providers?

Sovereign

Price	£	£	£
Timber Warranty	20 Years		
Wetpour HIC Guarantee	5 Years		
Playground Markings Warranty (ask that it covers both product and installation?)	5 Years		
Is the wood used from responsible sources?	FSC certified		
Is ALL the Equipment compliant to BS EN 1176?	Yes		
Is ALL the Safety Surfacing installed to BS EN 1177?	Yes		
Has the company got Public Liability insurance of £10,000,000 - required to work in local authority sites?	Yes		
Has the company got professional indemnity insurance, covering the design aspect of the works?	Yes		
Are references and case studies freely offered and included within the brochure and quotation packs?	Yes		
Do you receive an After Care manual with vital day to day safety advice and check lists?	Yes		
Does the company offer a regular safety inspection service?	Yes		
Are the Installation Teams, Delivery Drivers, Inspectors and Sales Team all DBS checked?	Yes		

Warranties and Accreditations



25 Year Metalwork
Warranty Against
Structural Failure



25 Year Structural
Guarantee on Metal
Gym Equipment
with 2 years
Guarantee on
moving parts (such
as bearings), 5 year
Guarantee on Paint



20 Year Timber
Warranty Against
Structural Failure



10 Year Warranty
on Timbers on
Residential Tower
Units



7 Years Warranty
covering defects in
manufacturing,
materials, the UV
degradation (Including
light fastness) and
excessive wear of
Needlepunch
Sport Surfacing



5 Year Warranty
Springs



5 Year Warranty
HDPE Coloured
Panels and Roofs



5 Year Warranty
Playground Markings



5 Year Warranty
Safety Surfacing



5 Year Warranty
Tower Platforms and
Floors



3 Year Warranty Swing
Seats and Chairs



2 Year Warranty
Bearings



1 Year Warranty on
Metal Gym
Equipment



1 Year Warranty
Powder Coating



1 Year Warranty
Installation

Exclusions to Warranties

All of the above warranties exclude normal wear and tear, improper use and deliberate, accidental and cosmetic damage.

During the warranty period, we will repair the faulty component, or replace the faulty part with a new component at our sole discretion. Components replaced or repaired during the warranty period will carry the unexpired portion of the original warranty.

All Sovereign equipment must undergo regular inspection and routine maintenance in accordance to Sovereign's Operation and Maintenance Manual, which can be obtained at no extra cost on request or downloaded from the Sovereign website at www.sovereignplayequipment.co.uk





Sovereign takes a responsible view towards the protection of the environment in which we live, and is a key part of Sovereign's principles. Every effort and consideration is made to the social and economic impact of the goods and services we supply.

Timber Components

All timber components are pressure-impregnated treated timber which is machine sanded and slow grown from responsible sources. All timber supplied is FSC (Forest Stewards Commission) certified which means that the amount of timber harvested does not exceed the amount of timber re-grown and guarantees a controlled chain of custody.



Design

At Sovereign, good design is not just about appearance and functionality, but also about how the life cycle of our products and components affect the environment we live in. All components are, whenever possible, sourced locally to promote local economic growth and reduce logistic costs, as well as helping lower emissions. All contribute in helping reduce the company's carbon footprint. All products produced by Sovereign have been designed to minimise waste whenever possible and promote waste and recycling policies.

Delivery and Logistics

Sovereign undertakes strict routine maintenance on our entire fleet of vehicles ensuring that they run to their optimum, so increasing fuel efficiency and reducing harmful gases. Sovereign also trains employees to drive in a manner designed to increase fuel efficiency and this is monitored and recorded through our Road Angel Tracking Program. Should you require any further information on any of Sovereign's environmental policies please do not hesitate to contact us.

The Extra Mile...

We are accredited with the world's most recognised environment management system ISO 14001, which provides the framework to allow us to meet high customer expectations of corporate responsibility, as well as legal and regulatory requirements. Sovereign takes a responsible view towards the protection of the environment in which we live and is a key part of Sovereign's principles. Every effort and consideration is made to the social and economic impact of the goods and services we supply.



» After Sales Service and Spare Parts



Inspection, Maintenance and Repair

At Sovereign we understand how important it is that our service does not stop on the completion of your installation. Each installation comes complete with a comprehensive maintenance manual which contains detailed information and a check list to help with routine maintenance.

Sovereign also offers a range of maintenance packages which are carried out by our national team of RPII qualified inspectors. Each inspection comes complete with a full report, together with recommendations and details of any necessary maintenance work.



Spare Parts

Parts that are subject to constant movement may eventually show signs of wear and tear and although every effort is made to design our components to last as long as possible, unfortunately spares may be required within the product's life span.

Our dedicated customer services department are able to provide advice on all our services and spares. Most spares are stored or manufactured at the Sovereign Headquarters and many can be dispatched for next day delivery.



The Extra Mile...

When products or components fail within the warranty period, many companies just send out the replacement parts. At Sovereign we go the extra mile and include the removal and reinstatement of any new parts.



Doddington Parish Council was approached by young people in the village who asked if a skate park could be built. From approval of their request to its official opening, the skate park took one year to complete and is a resounding success.

The issue:

Young people in the village wanted a skate park where they could meet to practice their skills in a safe, purpose-built environment.

The resolution:

Sovereign Design Play Systems Ltd was commissioned by the council to plan and build a custom-made skate park on the existing Abbey Recreation Field.

The process:

Funding was provided by way of grants from Fenland District Council and local businesses, Woodford Waste Management Services Ltd and AmeyCespa.

A Skate Park Management Committee was set up, comprising young people from the village, residents from the nearby Abbey Estate and Parish and District Councillors.

Various quotes for the work were obtained by the Parish Council and Sovereign was awarded the contract with a competitive and very detailed quotation, including a design concept that enabled all those involved to visualise the intended outcome.

The installation:

Preparatory work included ground clearance, levelling and the application of tarmac, then Sovereign installed a variety of steel ramps with skate lite surfacing, including two quarter pipes, a double wave, a beginner box and grind rail. Sovereign also installed seating and bins, and to try to discourage vandalism of the ramps and surfacing, a graffiti wall was erected to provide an alternative canvas for 'aspiring artists'.

High fencing was also installed on two sides to prevent footballs being kicked into the park from the neighbouring football pitches and a tarmac path was laid from the pavilion to the skate park to provide easy access for those with prams

or disabilities.

Sovereign was also on hand to help with the official opening ceremony for the skate park. In

addition to arranging for an MC to attend from ESPNs X-Games, Sovereign also arranged competitions and demonstrations by European tour riders.

The benefits:

- *Young people have a safe, purpose-built environment where they can practice their skills*
- *Youngsters can safely congregate, exercise and have fun without disturbing neighbouring homes*
- *The skate park promotes social interaction and inclusion, as well as a sense of pride and achievement*

"Once the final design was agreed, the contractors were on site and on time. The quality of work was excellent, and was carried out with a great deal of care, so as not to disrupt the infrastructure of the playing field upon which the skate park was built. The design of the park has been a big hit with youngsters of all ages." Ruth Hufton, Parish Councillor at Doddington Parish Council and Chair of the Skate Park Management Committee.

» "I was really impressed with the professionalism of Sovereign Sales Manager, Justin Mottaz, who I met on site on a number of occasions to discuss our needs. He was backed up by prompt and detailed information from his team, and nothing was too much trouble."

Ruth Hufton





Edwinstowe Parish Council in Nottingham has renovated a small play area in the middle of a housing estate, in their vibrant and busy village in the heart of Sherwood Forest; the home of the legendary Robin Hood.

The issue:

The parish council needed to renovate an existing playground under a strict budget. The original play area was outdated, offering children very limited scope for imaginative or challenging play.

The resolution:

Edwinstowe Parish Council wanted an interesting play space that would be suitable for children under the age of 13, whilst at the same time providing an attractive meeting place that appealed to family groups.

As it was an existing site, most of the equipment needed to be replaced, but some, for example, the swings, were still very serviceable. Sovereign worked their plan around what could be kept and designed a really interesting play space. Real regard was given to the budget constraints, ensuring the parish council received excellent value for money.

The process:

Various quotes for the work were obtained and Sovereign was awarded the contract, as the parish council felt they had a real understanding of their needs.

According to Alice Dunn, Parish Clerk at Edwinstowe, "Sovereign were really open to our ideas. We had involved our local children to see what they wanted from their play space and Sovereign interpreted those ideas into their designs."

The installation:

The open-plan, unfenced design features a wide range of timber structures and play equipment to answer the brief; offering unstructured play, and providing children of different ages with challenges befitting their abilities.

A wooden roof pergola and two round picnic tables and benches were installed to provide a social area and meeting place for family groups.

In addition to the practical and aesthetic solutions, Sovereign's design also ensured that the wide range of new play equipment blended perfectly with the equipment the parish council wanted to retain.

Included in the installation was one of the ideas suggested by the local children; a wooden adventure trail that would be suitable for the younger users. The result includes two balance weavers, clatter and drop rope bridges, a rope wall climber and a log traverse, interspersed with stepping stones and balance beams. Other equipment installed includes two adventure towers, the Cat and Mouse, and The Buzz.

The benefits:

- *The play area has become a real hub for community activity, with parents, grandparents and childminders meeting for a chat while their children play.*
- *Provides unstructured play to encourage physical, mental and social development.*
- *The picnic benches and shelter are attracting local mums who often meet for picnics.*
- *The area is purpose-built and safe, allowing children to play freely with minimal parental supervision required.*

» "From our first meeting to the completion of the construction, we felt that Sovereign was on our wave-length and because they listened and worked with us, we have got exactly what we want. The area, which was rarely used before, is now a lovely place to meet and play."

Alice Dunn, Parish Clerk,
Edwinstowe Parish Council



This Parish Council in Somerset has completed work on its play facilities to provide safe and durable, yet inspiring play equipment for children between the ages of two and fourteen.

Councillor Brenden Hill explains:

“Churchill Parish Council has always been committed to providing play facilities for the younger members of the Parish. Our areas currently include a skate board park, BMX track and a play area with an assortment of equipment available for children of all ages.

Over the past five years the Leisure Committee, a sub-committee of the main Council, rolled out a programme to replace equipment situated in the children’s play area. This was due to increased maintenance and the need to comply with the annual insurance inspection. The play area’s two wooden forts were of particular focus; the larger fort had been patched up over the years and the smaller fort too was nearing the end of its life – the committee agreed it was time to replace them.

“We undertook a consultation process with some of the children who use the play area, and with their needs in mind, we approached a number of play equipment companies. Sovereign was able to provide us with a competitive quote to replace both forts with the installation of a Combi and Fusion from its Benito range.

“The Sovereign team started work during September and the new equipment was installed and ready for use within one week. The Combo is designed for children from 2-8 years old and the Fusion caters for children aged 5-14. Since the project completion, we have received positive feedback from all of the children using the play area.”



» “We approached a number of play equipment companies and Sovereign was able to offer a competitive quote. The installation took one week and since the equipment has been in place, we have received positive feedback from all the children.”

Councillor Brenden Hill

Elmbridge Borough Council in Surrey has provided an exciting new play area for toddlers and young children in the Hurst Meadow area. Lying alongside the River Thames in Elmbridge, upstream of Hampton Court Bridge, Hurst Meadow is a popular open space and a lovely landscape, so the bespoke water and nature theme created by Sovereign was just right.

Elmbridge Borough Council wanted to replace equipment on the existing play area and was delighted with the idea to split the site into two distinct areas to appeal to toddlers and children up to the age of 11.

Sovereign's imaginative solution was to create two very different environments, one based on a water theme and the other based on nature.

The toddler area is inspired by the Thames which flows alongside the play area and incorporates a water theme for the safety surface; in the junior play area the safety surface reflects nature and took the beautiful Surrey landscape as its inspiration.

The two distinctly different areas created by Sovereign include two tailor-made play structures which incorporate a range of equipment including a toddler multi-play unit, a junior multi-play unit, log swings with flat seats and wet-pour safety services.

A clear brief and imaginative design led to a trouble-free installation. Once the design was presented to the Council and the proposal was accepted, Sovereign installed the equipment within the month.

Philip Robinson, Senior Parks Development Officer for Elmbridge Borough Council:

"We recently awarded a contract to Sovereign Design Play Systems to replace three items of play equipment at Hurst Meadow play area, following a competitive quotation procedure.

"Our qualitative and financial evaluation of the various returned submissions demonstrated that Sovereign could provide value for money by being able to cost effectively fulfil our brief.

"The installation was expediently completed and successfully passed the post installation inspection on the day.

"These improvements have made a valuable contribution to the area, and the safety surface graphics, themed to match the style of equipment, are the best we have seen so far in Elmbridge."



» "These improvements have made a valuable contribution to the area, and the safety surface graphics, themed to match the style of equipment, are the best we have seen so far in Elmbridge."

Philip Robinson, Senior Parks Development Officer
for Elmbridge Borough Council

Sovereign Design Play Systems Limited

Terms and Conditions



It shall be the duty of Sovereign Design Play Systems Limited (known hereafter as 'the Company') to provide You with the Goods and Services in accordance with the Order Confirmation provided to you and the terms and conditions ("T & C") as laid out below.

1. Definitions

- 1.1 "Authorised Person" means the person who places the Order and who is duly authorised by You to enter into a binding contract with Us.
- 1.2 "We or Our or Us" means the Company whose registered office is 40 Towerfield Road, Shoeburyness, Essex SS3 9QT, registered number 5024016, a company registered in England.
- 1.3 "Contract" the contract between You and Us (in whatever terms for the supply of goods and/or provision of services) to which these T&C relate (whether incorporated, appended or attached).
- 1.4 "Goods" means the Goods that We have agreed to supply You (including but not restricted to the equipment and component parts) as shown on the Order Confirmation.
- 1.5 "Order" your order for the Goods and/or Services as set out in your Purchase Order.
- 1.6 "Order Confirmation" means the document provided by Us upon receipt of the Order which confirms your Order and which you are obliged to return signed by an Authorised Person and in the event that it is not returned within 48 hours of your receipt, the Order Confirmation shall be deemed accepted by You and You will have no ability to cancel the Contract without liability to Us as set out below.
- 1.7 "Order Value" means the price set out on the Order Confirmation.
- 1.8 "Site" means the premises where the Goods are to be supplied and/or installed by Us.
- 1.9 "Services" means the services that We have agreed to provide You (including but not restricted to installation and any other preparatory or ancillary work), as shown on the Order Confirmation.
- 1.10 "T&C" means these terms and T&C or any subsequent variation thereof.
- 1.11 "You or Your", the person, company, firm or entity being party to the Contract and to whom Goods are supplied and/or Services are provided.

2. Offer and Acceptance

- 2.1 The Order constitutes the offer by You to purchase the Goods and/or Services in accordance with these T&C and You shall ensure that the Order is complete and accurate and has been placed by an Authorised Person.
- 2.2 The Order will not be accepted until We issue You with the Order Confirmation which will confirm the existence of the contract.
- 2.3 You are responsible for ensuring that the Order Confirmation provided by Us accurately reflects the Goods and/or Services that you wish Us to supply to You and to notify of any discrepancies within 48 hours of your receipt.
- 2.4 These T&Cs shall apply to all Goods and/or Services provided by Us to You to the exclusion of all other terms and T&C, including any terms or T&C which you may purport to apply to the Contract under any purchase order that you supply and no variation of these T&C shall be binding unless agreed in writing by Us and attached hereto.
- 2.5 The Company's employees or agents are not authorised to make any representations concerning the Goods and/or Services unless confirmed by Us in writing and in entering into the Contract to purchase Goods and/or Services you acknowledge that you do not rely on any such representations which are not so confirmed.
- 2.6 If the Goods are to be manufactured or any process is to be applied to the Goods by the Company in accordance with a specification submitted by You, You shall indemnify Us against all losses, damages, costs and expenses incurred by us in connection with settlement of any claim for infringement of any patent, copyright, design right, trade mark or other intellectual property rights of any other person which results from our use of your specification.
- 2.7 The Company reserves the right to make changes in the specification of the Goods which are required to conform to any applicable statutory or EU requirements.

3. Commencement Date and Delay

- 3.1 You shall make all necessary arrangements to take delivery of the Goods whenever they are tendered for delivery by Us (including outside normal business hours), and You must ensure that an authorised representative is present at the time of delivery in order to ensure access to the site and to authorise and our enable delivery of the Goods.
- 3.2 Where the Goods are to be delivered in instalments, each instalment shall constitute a separate contract into which these T&Cs shall be incorporated. Failure by the Company to deliver any instalment shall not entitle You to treat these T&C as repudiated.
- 3.3 Any dates quoted for delivery or installation of the Goods are approximate only and the Company shall not be liable for any delay in the delivery or installation of the Goods howsoever caused, including any delay caused by Force Majeure Event, because of your failure to provide us with adequate delivery instructions or any other instructions that are relevant to the supply or installation of the Goods. Time for delivery shall not be of the essence unless previously agreed in writing by Us.
- 3.4 The Company may install or deliver the Goods in advance of the quoted delivery date upon giving You reasonable notice, and may also deliver at a date earlier than the proposed installation date. You must advise us at the time of placing your Order if this is not acceptable as subsequent variations may affect the delivery date, installation date and price.
- 3.5 If the Company fails to deliver the Goods (or any instalment) for any reason other than any cause beyond our reasonable control or Your fault, and We are accordingly liable to You for delay, Our liability shall be limited to the excess (if any) of the cost to You (in the cheapest available market) of similar goods to replace those not delivered over the price of the Goods,
- 3.6 If You fail to take delivery of the Goods, fail to give Us adequate delivery instructions at the time stated for delivery or fail to permit us to install the Goods, then the Company reserves the right to:
 - 3.6.1 Store the Goods until delivery to You and charge You for the reasonable costs (including insurance) of storage; and/or
 - 3.6.2 Sell the Goods at the best price readily obtainable and after deducting all reasonable storage and selling expenses or charge You for any shortfall below the agreed price;
 - 3.6.3 Charge You an abortive fee of £200 per half-day or £400 per full day, deemed to exclude all applicable VAT. We will reschedule your delivery and/or installation, but there may be a consequential delay and charges applied.

4. Access for Installation

- 4.1 You must ensure that an authorised representative is present at the site at the time of installation or any preparatory work being carried out in order to ensure access to the Site and provide confirmation as to design and layout.
- 4.2 We will cordon off the installation area using temporary orange fencing (during works, replacing with barrier tape upon completion). If You require more substantial fencing, You must advise Us timeframe before the agreed delivery date, The Order Confirmation and price will be altered accordingly.
- 4.3 Any dates quoted for installation or any preparatory works are approximate only and We shall not be liable for any delay howsoever caused. Time for installation shall not be of the essence unless previously agreed in writing by Us. Where We need to change an installation or preparatory work date, We will provide You with at least 24 hours' prior written notice, whenever practical,
- 4.4 You acknowledge that installation of floor markings, surface and other specialist goods are completed by different teams and may not take place on the same day as installation of the Goods.
- 4.5 You acknowledge that We may need access to the Site outside of normal business hours.
- 4.6 Although We shall take reasonable steps to avoid causing damage to floor, surfaces and access routes, We shall not be liable for such damage (unless caused by our negligence or wilful default) when You have given us permission to access such floor, surface or access routes.

5. Limitation of Liability

- 5.1 We warrant to you that any Goods purchased from Us are of satisfactory quality, and reasonably fit for purpose for which Goods of their kind are commonly supplied, and will be useable for a minimum period of 12 months from delivery, provided they are maintained in accordance with the relevant maintenance guidelines that we or the manufacturer of the Goods may provide.
- 5.2 We shall not be liable for the failure of the goods to comply with the warranty set out in clause 14.1 if:
 - 5.2.1 the defect arises because you failed to follow our oral or written instructions as to the storage, commissioning, use and maintenance of the Goods or (if there are none) good trade practice; or
 - 5.2.2 you alter or repair such Goods without our written consent; or
 - 5.2.3 The defect arises as a result of fair wear and tear, willful damage, negligence, or abnormal storage or working T&C.
- 5.3 Our liability for losses you suffer as a result of Us breaching the Contract is strictly limited to the purchase price of the Goods you purchased.
- 5.4 This does not include or limit in any way our liability: 5.4.1 For death or personal injury caused by our negligence; 5.4.2 Under section 2(3) of the Consumer Protection Act 1987; 5.4.3 For fraud or fraudulent misrepresentation; or 5.4.4 For any matter for which it would be illegal for us to exclude, or attempt to exclude, our liability.
- 5.5 We are not responsible for indirect losses which happen as a side effect of the main loss or damage and which are not foreseeable by you and us, including but not limited to any or all of the following: loss of income or revenue; loss of business; loss of profits or contracts; loss of anticipated savings; loss of data, or waste of management or office time however arising and whether caused by tort (including negligence), breach of contract or otherwise; provided that this clause 5.5 shall not prevent claims for loss of or damage to your tangible property that fall within the terms of clause 5.1 or clause 5.2 or any other claims for direct financial loss that are not excluded by any of the provisions of this clause 5.5.
- 5.6 Except as set out in these T&C, all warranties, conditions and other terms implied by statute or common law are, to the fullest extent permitted by law, excluded from the Contract.
- 5.7 These T&C shall apply to any repaired or replacement Goods supplied by us.
- 5.8 No claim for damage in transit, shortage of delivery or loss of Goods shall be accepted by the Company for consideration unless:
 - 5.8.1 In respect of damage in transit or short delivery, You provide notice to Us within three days of receipt of the Goods, and within five days thereof send a complete claim in writing to us; and/or
 - 5.8.2 In respect of loss of Goods, You provide notice to Us in writing within ten days of the date of consignment of the Goods sends a complete claim in writing to Us; and
 - 5.8.3 a written claim pursuant to this clause shall state the advice note number, condition of package, date consignment received and extent of damage or shortage.
- 5.9 All leaflets, specifications, drawings and particulars of prices, weights, dimensions, colours and performance issued by us are approximate only and are not intended to form the basis of any contract between you and us.
- 5.10 You undertake to comply with the General Goods Safety Regulations 1994 to the extent that they apply to the Goods.
 - 5.11 It shall be Your responsibility to advise Us of any issues known to You in respect of the surface to which the Goods will be affixed, and in the event that it is later determined that such issues were not declared, We shall have no responsibility for any remedial works and/or losses.
 - 5.11.1 You undertake to indemnify the Company in respect of any and all claims arising from the Goods being unsafe as a result of your activities.
 - 5.11.2 You agree to monitor the safety of the Goods once installed, to pass on any information on the risks of the Goods and to co-operate in any action we may decide to take to avoid those risks.
 - 5.11.3 You acknowledge receipt of any important health and safety notification that we may provide relating to the installation of the Goods and associated floor markings.
 - 5.11.4 We will provide the Goods in accordance with BSEN 1176/1177, We do not warrant or represent that the Goods will comply with any other standard or quality mark.
 - 5.11.5 Except in respect of death or personal injury caused by our negligence, the Company shall not be liable to You by reason of any representations (unless fraudulent), or compliance with any instruction or consent given by You or on Your behalf by an Authorised Person, or any implied warranty, condition or other term, or any duty at common law or under the express terms of the Contract, for any indirect, special or consequential loss or damage (whether for loss of profit or otherwise), costs, expenses or other claims for compensation whatsoever (whether caused by our negligence or our employees, agents or otherwise) which arise out of or in connection with the supply or installation of the Goods or their use by You, and our entire liability under or in connection with the Contract shall not exceed 110% of the price of the Goods, except as expressly provided in these T&Cs.

6 Passing Of Property and Risk

- 6.1 Whilst risk in the Goods shall pass to You from the time of delivery, legal and beneficial ownership of the Goods shall remain with Us until such time as we have received payment in full in respect of all sums owing from You to Us.
- 6.2 Until such time title to the Goods has passed to You, you shall:
 - 6.2.1 keep the Goods separate from your property and that of any third party and clearly identified as being the property of the Company;
 - 6.2.2 Until title to the Goods has passed to you, you shall: (a) hold the Goods on a fiduciary basis as the our bailee; (b) store the Goods separately from all other Goods held by you so that they remain readily identifiable as our property; (c) not remove, deface or obscure any identifying mark or packaging on or relating to the Goods; (d) maintain the Goods in satisfactory condition and keep them insured against all risks for their full price from the date of delivery; and (e) notify us immediately if it becomes subject to any of the events listed in clause 13.1. If before title to the Goods passes to you, you becomes subject to any of the events listed in clause 13.1, or we reasonably believe that any such event is about to happen and we notify you accordingly, then, provided that the Goods have not been resold, or irrevocably incorporated into another Goods, and without limiting any other right or remedy we may have, we may at any time require you to deliver up the Goods and, if you fail to do so promptly, enter any of your premises or of any third party where the Goods are stored in order to recover them.
 - 6.3 Without prejudice to our warranty set out at clause 14, you must notify us within 48 hours of delivery if the Goods are defective or damaged or the delivery is short.
- 6.5 In the event that You engage any works to be undertaken to Goods supplied by Us by any third party not authorised by the Company, the Company will have no further responsibility or provide any warranty for the Goods and will not be responsible for any claims.
- 6.6 All transportation charges relating to the return of Goods will be borne by You unless otherwise agreed in writing, and the risk in the Goods shall remain with You until the Goods are received by us and any Goods so returned are despatched by you at your own risk.

Sovereign Design Play Systems Limited

Terms and Conditions



6.7 You shall not be entitled to reject part only of the Goods delivered in accordance with these T&Cs.

6.8 Any claims against Us for Goods not credited or replaced will only be considered where you can provide proof of delivery to Us,

6.9 The Company will at our discretion replace whenever possible Goods found to be of faulty manufacture after examination provided that the Goods have been returned in accordance with these T&C. We will return goods after examination if they are found to have no fault or defect,

7 Instructions

If the signing-off of our installation of Goods is dependent on a third party (e.g. Council, H&S Executive), you must inform us upon placing your order and this will be confirmed in the Order Confirmation as subsequent and later notification may affect the delivery date, installation date, price and payment terms.

8 Cancellation of Order

8.1 No Order Confirmation once provided by Us may be cancelled by You without Our written consent once returned duly signed by an Authorised Person or after a period of 48 hours has elapsed following your receipt of the Order Confirmation, save for as set out in clause 8.3 below.

8.2 If an Order is cancelled by You within 48 hours of your receipt of the Order Confirmation, and our written consent is provided for the cancelled order, We are entitled to charge You a fee of 20% of the Order value, to a maximum of £1,000.

8.3 If an Order is cancelled after 48 hours from your receipt of Order Confirmation, and our written consent is given for a cancelled Order, We are entitled to charge You a fee of 50% of the full Order Value.

9 Defects

9.1 Any claim by You which is based on any defect in the quality or condition of the Goods or their failure to correspond with specification or the installation of the Goods shall be notified to Us within 48 hours of the date of delivery or (where the defect or failure was not apparent on reasonable

inspection) within a reasonable time after discovery of the defect or failure but not more than one year after delivery and such Goods shall be returned with written notification which must state the nature of the fault of each item and the invoice number in relation to the purchase of each item.

9.2 If delivery is not refused, and You do not notify us accordingly, You shall not be entitled to reject the Goods and we shall have no liability for such defect or failure, and You shall be bound to pay the Order Value as if the Goods had been delivered in accordance with the Order Confirmation.

9.3 Where any valid claim in respect of any of the Goods, which is based on any defect in the quantity or condition of the Goods or their failure to meet specification is notified to Us in accordance with these T&C, We shall be provided with the first opportunity to repair or replace the Goods (or the part in question) free of charge or, at our discretion, refund to you the price of the Goods (or a proportionate part of the price), but we shall have no further liability to you;

9.4 If you require Goods to be returned to Us because you claim that the Goods are in breach of clause 14.1, you must first contact our Customer Services team. For the avoidance of doubt, if any specific part of the Goods supplied is in breach of clause 14.1, your entitlement is for Us to inspect that or those parts, and not the entire Goods. We will arrange for an examination of the Goods to take place either at the place of delivery or the place of installation of the Goods and we will notify you whether we will repair or replace the Goods if they are defective, or alternatively whether we will provide a refund. If we are to provide you with a refund, we will usually process the refund due to you as soon as possible and, in any case, within 30 days of the day we confirmed to you that you were entitled to a refund for the defective Goods. Goods returned by you because of a defect will be refunded in full, including a refund of the delivery charges for sending the item to you and the cost incurred by you in returning the item to us. In the event that the Goods are collected by us, you will not receive payment for the costs incurred by Us in collecting the Goods. Goods returned for any other reason may be collected by Us although we will levy a collection charge which shall be confirmed to you in writing by our Customer Service Team when collection is arranged or if the Goods to be returned are able to be returned by You directly, there will be a minimum charge of twice the delivery rate appropriate for the Delivery Location and an administrative charge equal to 5% of the order value plus VAT, and such charges shall be confirmed to you by our Customer Service team. We will usually refund any money received from you using the same method originally used by you to pay for your purchase.

9.5 Where a defect is notified to us in accordance with the provision set out above, and you have not yet paid the full Price, you shall be entitled to retain up to 10% of the Price until the defects have been remedied.

10 Charges and Payments

10.1 Any price quoted on our Order Confirmation shall be deemed to exclude all applicable VAT unless otherwise stated. You shall, on receipt of a valid VAT invoice from Us, pay such additional amounts in respect of VAT as are chargeable on the supply of the Goods.

10.2 We reserve the right, by giving notice to you at any time before delivery, to increase the price of the Goods and will update our Order Confirmation to reflect any increase in the cost to Us which is due to any delay caused by your instructions, any change to those instructions or failure to provide adequate instructions,

10.3 All sums due to Us shall be payable in cleared funds within the timeframe agreed and as confirmed to You by Us within our Order Confirmation. If you fail to pay all sums due to Us on the due dates for payment then without prejudice to any other rights the Company may have, the company shall be entitled:

10.3.1 To cease taking further orders from You, and withhold further delivery of Goods for existing orders.

10.3.2 To demand immediate payment of all or any sums invoiced to You by the Company whether due at the date of the demand or not.

10.4 Payment shall be made by You without deduction or set-off, and shall be made notwithstanding any delay in obtaining such sign-off of the instalment by any third party (e.g. Council, H&S Executive).

10.5 If any minor or remedial issues in relation to the delivered Goods are reported in accordance with clause 9.1 above, You may retain a maximum of 10% of the Contract Price until such time that the minor or remedial issue has been resolved.

10.6 Where We have agreed a special discount, payment or other terms with

You, these shall be strictly subject to your compliance with these T&C, and such T&C shall cease and revert to our standard terms upon your non-compliance.

10.7 We shall be entitled to charge interest (calculated pro rata on a daily basis

and claim compensation on overdue accounts from the date payment is due in accordance with the Late Payment of Commercial Debts (Interest) Act 1998 (as amended) until the date of actual payment,

10.8 If Goods are credited it will be at the invoice price stated on the return application sheet and agreed by Us in writing.

10.9 In the event that during the course of the Services provided by us and/or the provision of any Goods to be supplied, it is determined that due to unforeseen circumstances, additional costs will be incurred due to additional Goods and/or Services being required, We will notify you in writing of the additional costs and You will be liable to cover such additional costs in order to enable the original Services and/or Goods to be provided.

11 Guarantees and Intellectual Property

11.1 We shall make reasonable endeavours to pass on to You the benefit of any guarantees or warranties given by any manufacturers of the Goods.

11.2 We hereby grant to You a non-exclusive and non-transferable licence to use such of our intellectual property rights as may be reasonably necessary for you to comply with your obligations under the contract. Such licence shall terminate automatically upon Your completion of the final act required of you to comply with such obligations.

11.3 If any claims are made or any action brought against You in respect of any infringement of an intellectual property right by the use or sale of Goods supplied by us, you must immediately give us written notice with full particulars of such claim or action.

12 Entire Agreement

These T&Cs (together with the terms (if any) set out in the Contract, the Order Confirmation constitute the entire agreement between the parties, supersede any previous agreement or understanding and may not be varied except in writing between the parties.

13 Termination

13.1 If You become subject to any of the events listed in clause 14.2, or we reasonably believe that you are about to become subject to them, then without prejudice to any other rights We may have, We shall be entitled

13.1.1 to withhold delivery of any undelivered Goods and to stop any Goods in transit and the installation of the Goods

13.1.2 we reserve the right to cancel the Contract or suspend any further deliveries under the Contract without any liability to you, and if the Goods have been delivered but not paid for, the price shall become immediately due and payable notwithstanding any previous agreement to the contrary.

13.1.3 to enter upon your premises and take possession of the Goods; and/or to re-sell the Goods or such of them as we deem necessary in order to recover the amount due and payable to us together with any costs incurred by us in taking such steps and you expressly and irrevocably authorise us to enter and take all necessary and reasonable steps upon your premises.

13.2 For the Purposes of clause 13.1, the relevant events are:

13.2.1 You suspend, or threaten to suspend, payment of your debts or are unable to pay your debts as they fall due or admit inability to pay your debts or (being a company) are deemed unable to pay your debts within the meaning of section 123 of the Insolvency Act 1986, or (being an individual) you are deemed either unable to pay your debts or have no reasonable prospect of so doing, in either case, within the meaning of section 268 of the Insolvency Act 1986, or (being a partnership) has a partner to whom any of the foregoing apply; or

13.2.2 you commence negotiations with all or any class of your creditors with a view to rescheduling any of your debts, or you make a proposal for or enter into any compromise or arrangement with your creditors; or

13.2.3 (being an individual) you are the subject of a bankruptcy petition or order; or

13.2.4 a creditor of yours attaches or takes possession of, or a distress, execution, sequestration or other such process is levied or enforced on or sued against, the whole or any part of your assets and such attachment or process is not discharged within 14 days; or

13.2.5 (being a company) an application is made to court, or an order is made, for the appointment of an administrator or if a notice of intention to appoint an administrator is given or if an administrator is appointed over you; or

13.2.6 (being a company) a floating charge holder over your assets has become entitled to appoint or has appointed an administrative receiver; or

13.2.7 a person becomes entitled to appoint a receiver over your assets or a receiver is appointed over your assets; or

13.2.8 any event occurs, or proceeding are taken, with respect to you in any jurisdiction to which you are subject that has an effect equivalent or similar to any of the events mentioned in clause 13.2.1 to 13.2.8 (inclusive); or

13.2.9 You suspend, threaten to suspend, cease or threaten to cease to carry on all or substantially the whole of your business; or

13.2.10 your financial position deteriorates to such an extent that in our opinion your capability adequately to fulfill your obligations under the Contract has been placed in jeopardy

13.3 We will not be liable to you or deemed to be in breach of contract by reason of delay or failure to perform any of Our obligations if the delay or failure due to acts caused beyond Our reasonable control.

14 Warranty

14.1 We make no express warranties and specifically disclaim any implied warranties, including any implied warranty of merchantability or fitness for a particular purpose, with respect to the performance of Services and/or the supply of Goods under these T&Cs to the extent permissible by law.

14.2 We do not guarantee, and nothing contained in these T&Cs shall be construed as a guarantee, that the Services performed or to be performed by Us will achieve any projected level of results.

14.3 Should You for any reason need to make a warranty claim, You must complete and return a claim form which can be obtained by contacting Us.

15 Confidentiality

The parties agree not at any time during or after the Term to divulge or allow to be divulged to any person any Confidential Information relating to the business or affairs of the other party to the Contract except as permitted by law or with the other party's consent.

16 Force Majeure

16.1 The Company shall not be liable for any default (or be deemed to be in breach of contract) by reason of any delay due to any occurrence beyond its reasonable control ("Force Majeure Event").

16.2 A Force Majeure Event includes any act, event, omission or accident beyond our reasonable control and includes in particular (without limitation) the following:

(a) Strikes, lock-outs or other industrial action. (b) Civil commotion, riot, invasion, terrorist attack or threat of terrorist attack, war (whether declared or not) or threat or preparation for war. (c) Fire, explosion, storm, flood, earthquake, subsidence, epidemic or other natural disaster. (d) Impossibility of the use of railways, shipping, aircraft, motor transport or other means of public or private transport. (e) Impossibility of the use of public or private telecommunications networks. (f) The acts, decrees, legislation, regulations or restrictions of any government.

16.3 Our performance under any Contract is deemed to be suspended for the period that the Force Majeure Event continues, and we will have an extension of time for performance for the duration of that period. We will use our reasonable endeavours to bring the Force Majeure Event to a close or to find a solution by which our obligations under the Contract may be performed despite the Force Majeure Event.

17 General Matters

17.1 No waiver by us of any breach of the contract by you shall be considered as a waiver of any subsequent breach of the same or any other provision,

17.2 If any provisions of these T&C are held by any competent authority to be invalid or unenforceable in whole or in part, the validity of the remainder shall not be affected,

17.3 These T&C and the contract shall be governed by English law and any dispute shall be submitted to the exclusive jurisdiction of the English courts,

17.4 These T&C do not purport to confer a benefit on any third party.

17.5 The Contract between you and us is binding on you and us and on our respective successors and assigns.

17.6 You may not transfer, assign, charge or otherwise dispose of a Contract, or any of your rights or obligations arising under it, without our prior written consent.

17.7 We may transfer, assign, charge, sub-contract or otherwise dispose of a Contract, or any of our rights or obligations arising under it, at any time during the term of the Contract.

17.8 We have the right to revise and amend T&C at any time to reflect changes in market T&C affecting our business, changes in technology, changes in payment methods, changes in relevant laws and regulatory requirements and changes in our system's capabilities.

17.9 You will be subject to the policies and terms and T&C in force at the time that you order Goods from us, unless any change to those policies or these T&C is required to be made by law or governmental authority (in which case it will apply to orders previously placed by you), or if we notify you of the change to those policies or these T&C before we send you the written confirmation in accordance with clause 2.3 (in which case we have the right to assume that you have accepted the change to such T&C, unless you notify us to the contrary within 48 hours of receipt by you of the Goods).

18 Notices

Any notices required or permitted to be given by either party to the other under these T&C shall be in writing addressed to the other's principal place of business.



SOVEREIGN

Bringing imagination into play

Company Name

Sovereign Design Play Systems Limited

Registered Address

40 Towerfield Road
Shoeburyness
Essex
SS3 9QT

Company Registration No

5024016

Company VAT Registration No

832 5102 64

Insurance

Public Liability: £10,000,000
Professional Indemnity: £5,000,000
Employers Liability: £10,000,000

01702 291129

www.sovereignplayequipment.co.uk

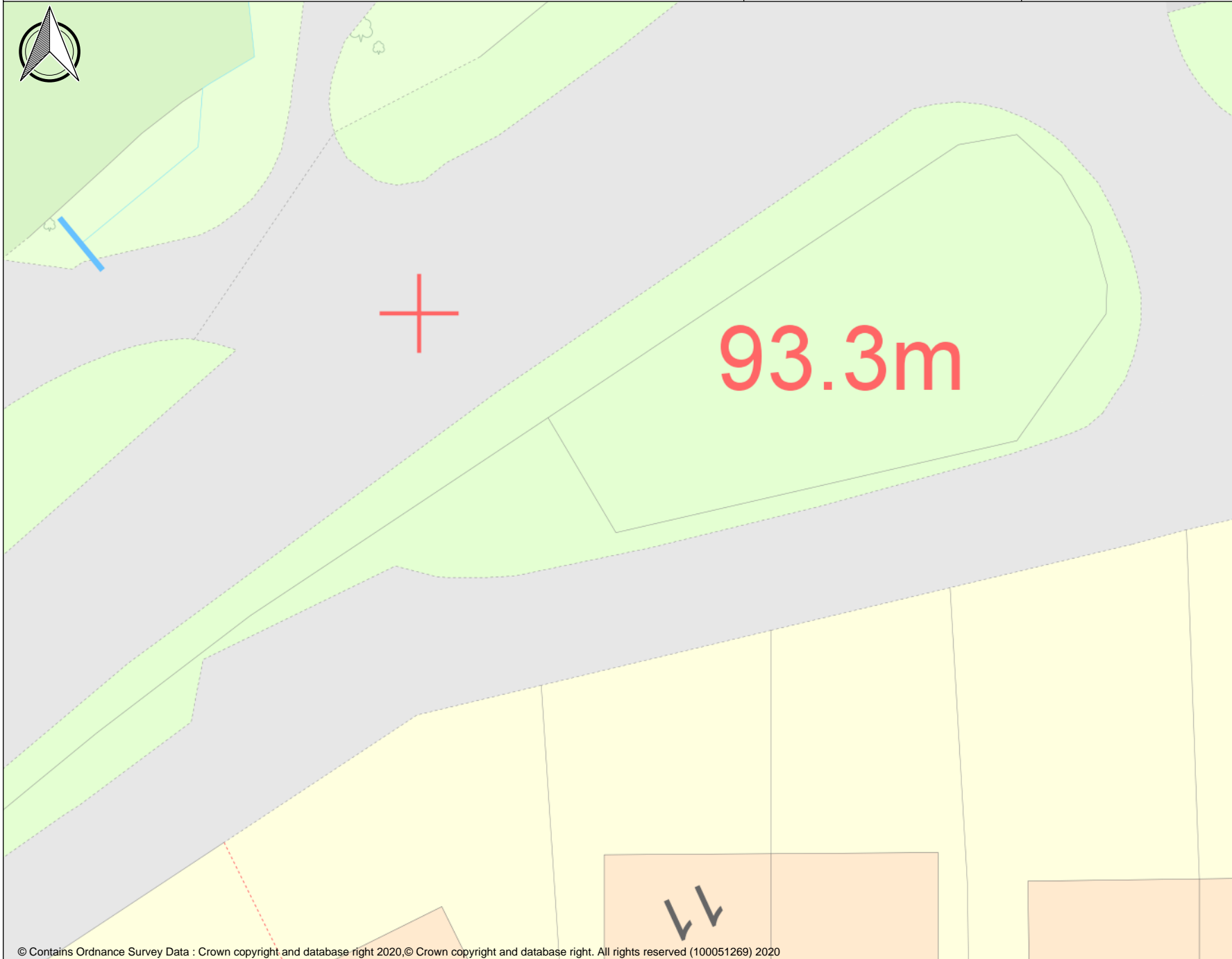

Playground Equipment

raster

Polygon

Line

Point

Parish



eibe play Ltd. | Forsyth's Home Farm, A3 By Pass Road,
Hurtmore, Godalming | Surrey GU8 6AD

 Playground | Furnishings | Sports & Toys

Wickhambrook Parish Council
Memorial Social Centre
Cemetery Road
Suffolk
CB8 8XP

1st June 2020

Reference: 60129115/60129109- New Junior Climbing Unit Options

Dear Hilary,

Thank you for inviting me to provide you with a quotation for the installation of your new climbing unit to your play space in Wickhambrook. Below we have highlighted our understanding of your requirements and our assumptions with regards to the installation.

eibe's Understanding of Your Requirement

We understand that your requirements are:

- Installation of a replacement Junior play unit
- Required amount of safer surfacing

Our Assumptions are:

- We assume good access to the site at the time of the install
- We assume that the current site is a level grassed area
- Further site visits needed by an eibe Play Project Manager

Play features of the Bain Climbing Unit:

- Fireman's Pole
- 1.45m Stainless Steel Slide
- Ramp Assent
- Banister Slide
- Metal post feet

eibe play Ltd.
eibe House, Home Farm
A3 By Pass Road
Hurtmore Godalming
Surrey GU8 6AD
Tel. 01483 813 834
Fax 01483 813 851

eibe@eibe.co.uk

Registration No:
2642028

VAT Registration No:
561 2861 144

Barclays Bank Ltd.
Account: 60019704
Sort Code: 20-35-35

Managing Director
of company:
Paul Redden

www.eibe.co.uk

Play features of the Alvier Climbing Unit:

- Fireman's Pole
- 1.45m Stainless Steel Broad Slide
- 0.95cm GRFP Slide
- Monkey Bars
- Metal post feet

Added Extras:

- Increased guarantee on equipment to 15 years
- Maintenance training workshop

Bain Climbing Unit Options:

We are pleased to provide you with a competitive price of **£17,383.87** plus vat for the installation of this fantastic new play addition. This includes the laying of a grass matting safer surface. We have been able to secure up to 10% discount on this scheme.

Alivier Climbing Unit Options:

We are pleased to provide you with a competitive price of **£20,233.08** plus vat for the installation of this fantastic new play addition. This includes the laying of a grass matting safer surface. We have been able to secure up to 10% discount on this scheme.

Please note this price includes all labour, plant and welfare and a grass matting safer surface.

I and my colleagues here at eibe Play, are really looking forward to working alongside you on this project, and look forward to seeing you all again in due course.

Yours Sincerely,

Stuart Evans
UK Sales Coordinator

07825 215074
sevans@eibe.co.uk

Bain Unit

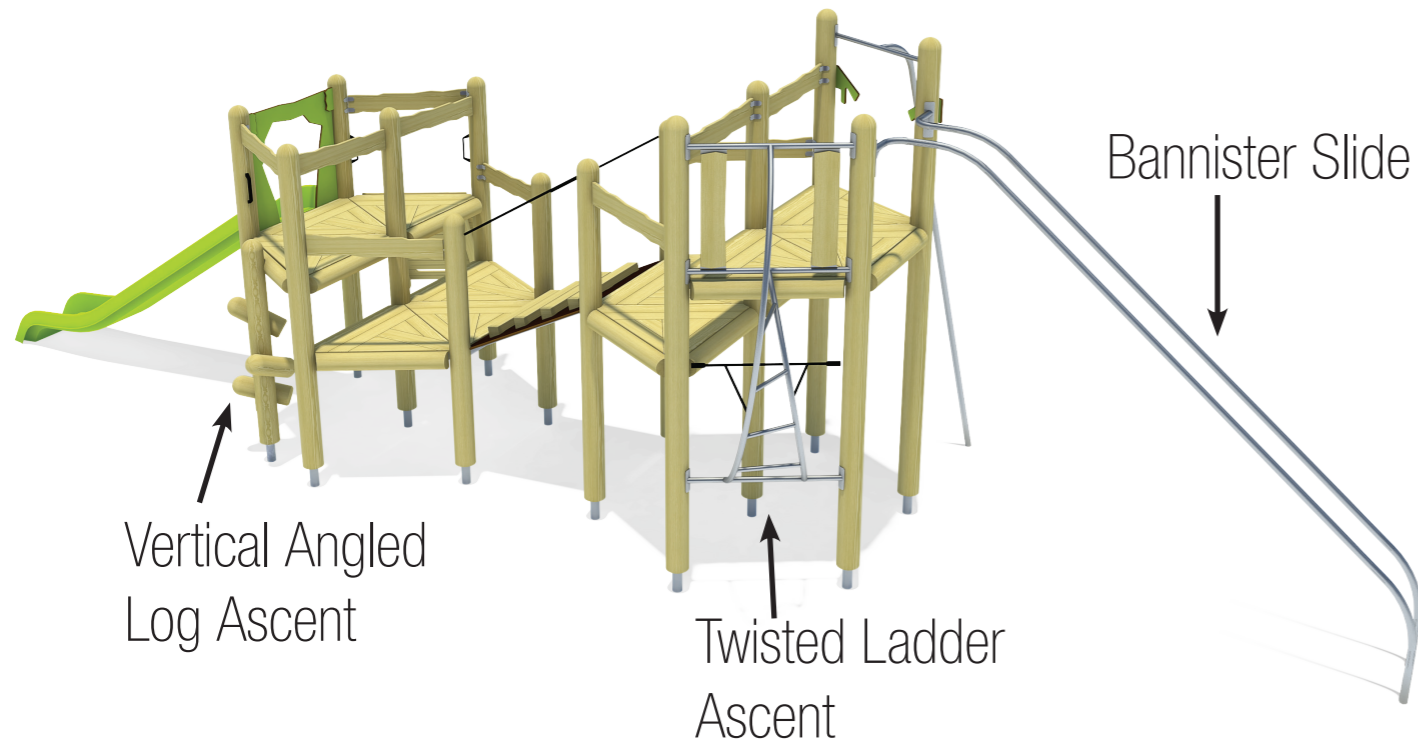
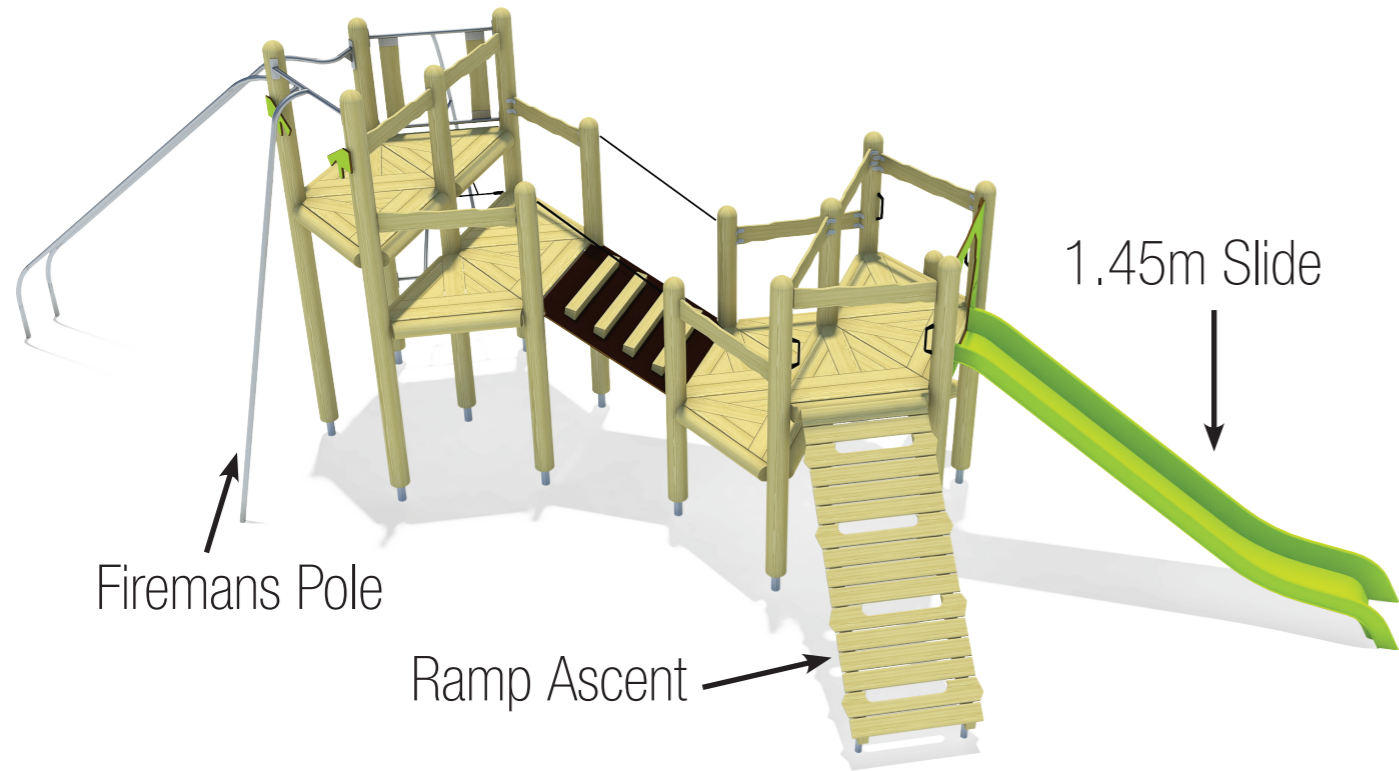

Alvier Unit

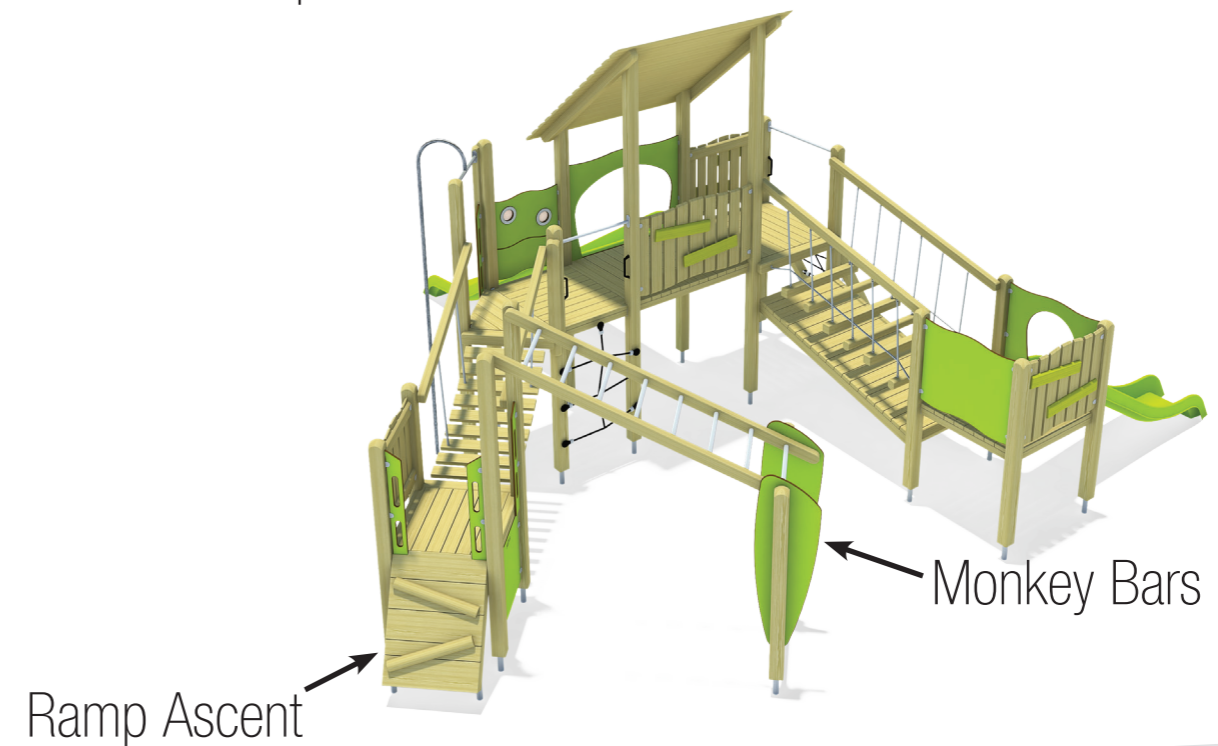

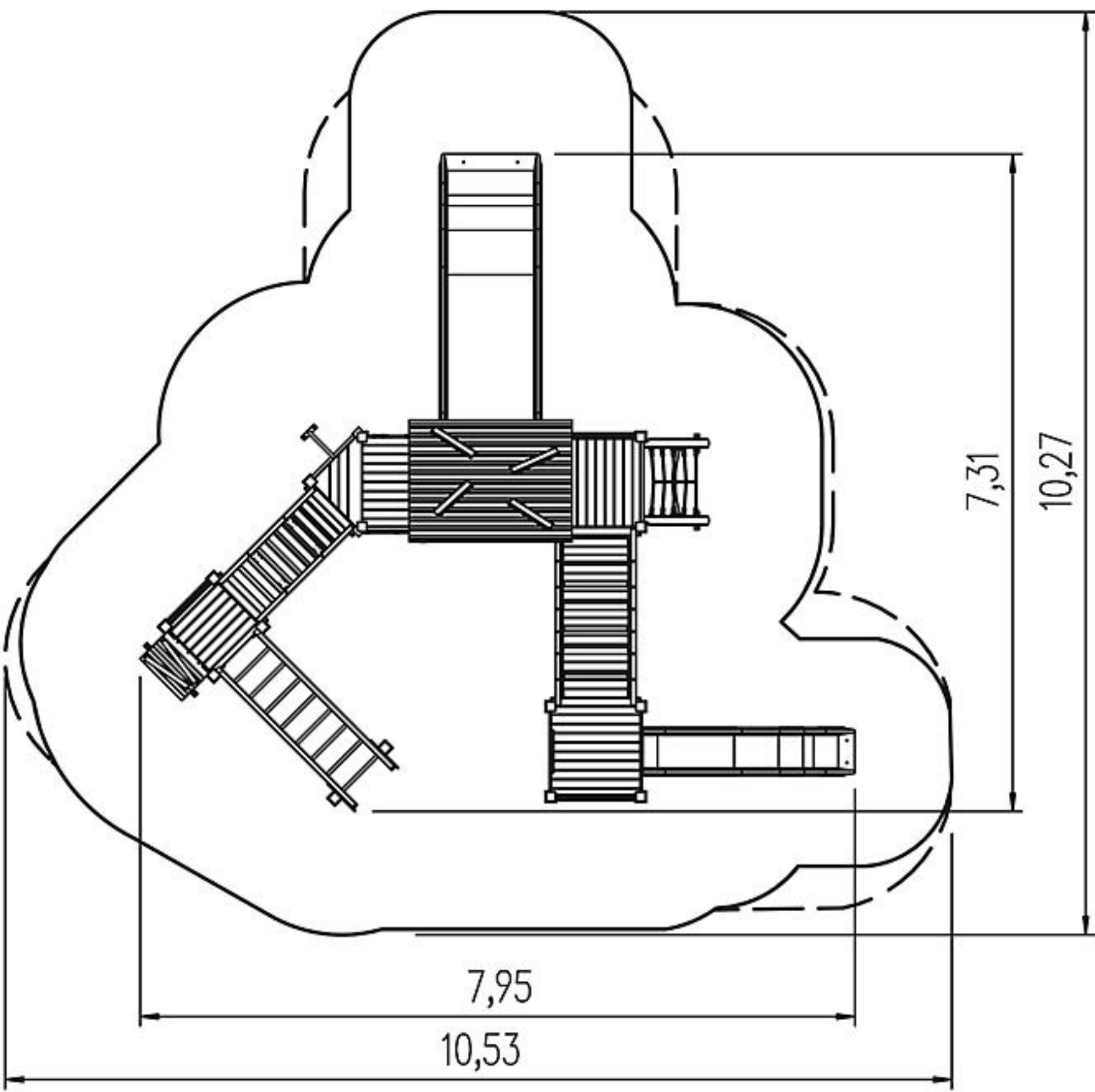
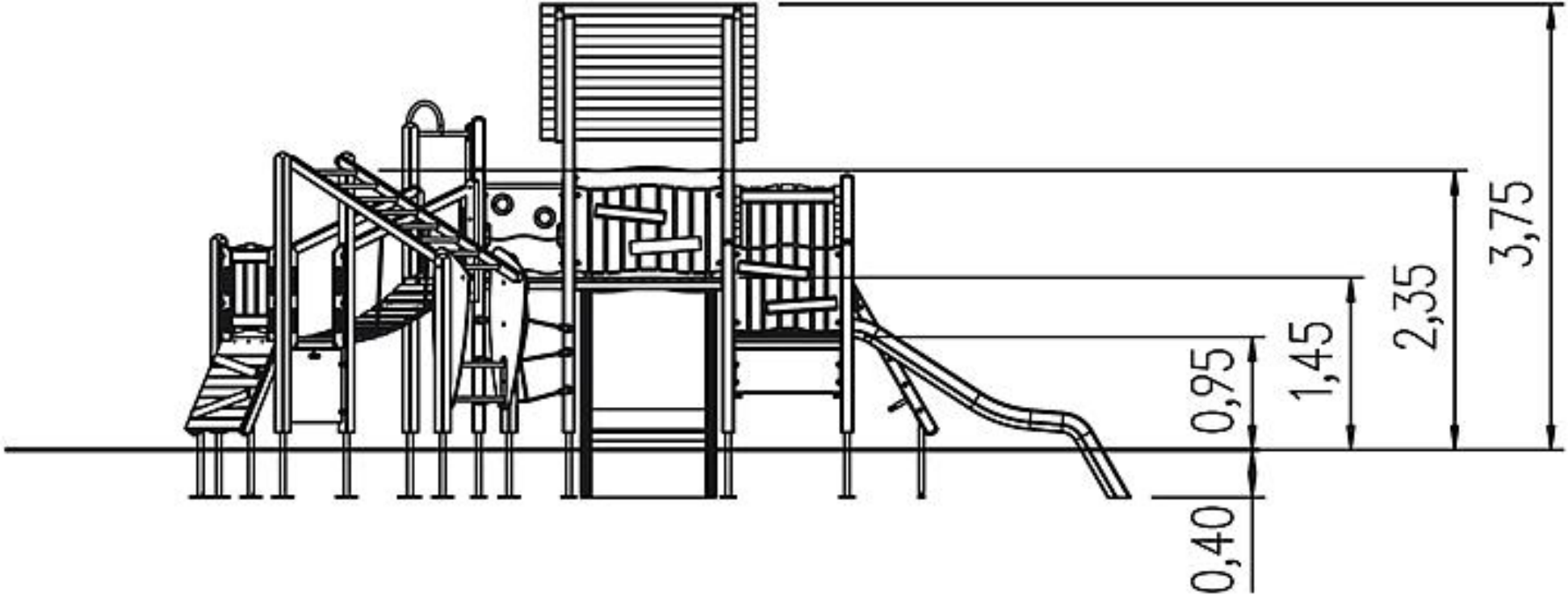

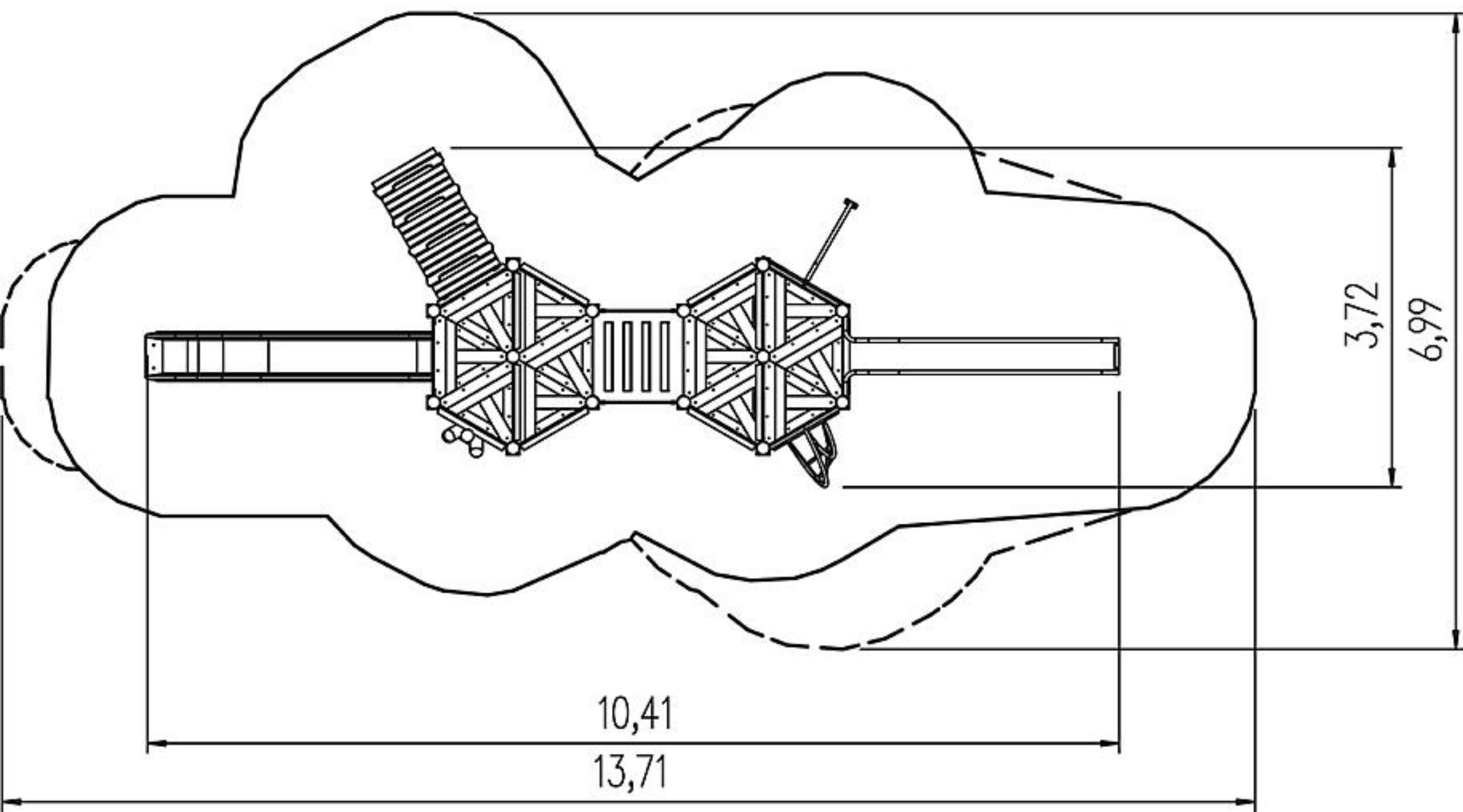
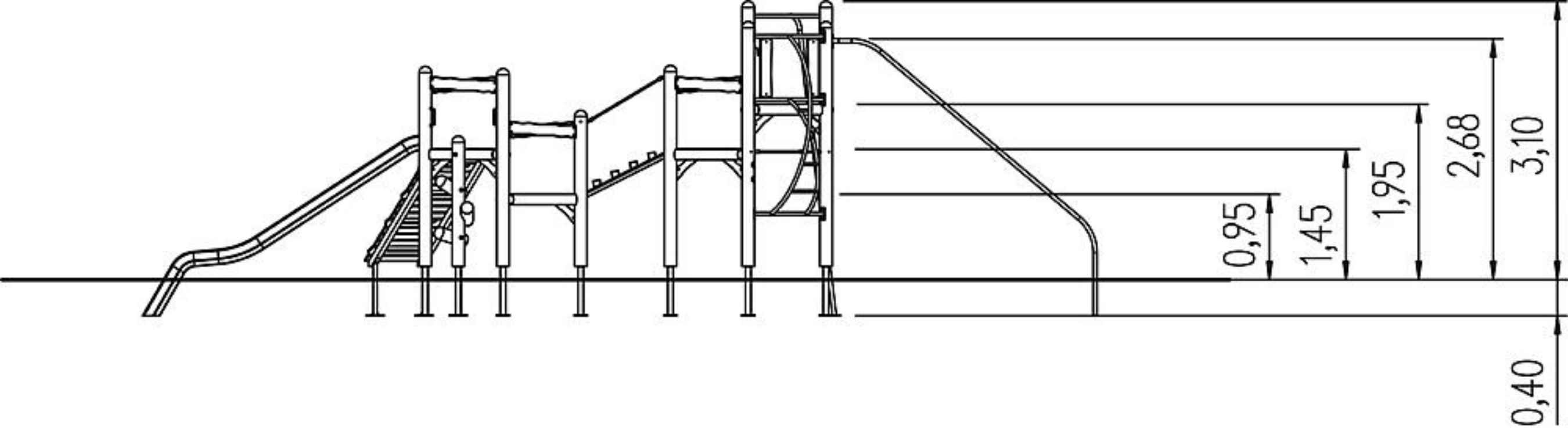

From: John Hambrook <john.hambrook@playforce.co.uk>
Sent: 15 July 2020 10:08
To: Hilary Workman <parishclerk@wickhambrook.org.uk>
Subject: RE: Playforce - Bury Road Play Area

Hi Hilary,

Yes this includes for new posts.

We can supply either timber or steel fencing as well. Painted or galvanised either 1 or 1.2m high flat or bow top style.

There are lots of options!

Many thanks

John

John Hambrook
Sales Manager

Playforce, 1 Pegasus Way, Bowerhill Industrial Estate, Melksham, Wiltshire, SN12 6TR

Tel: 01225 792660
Mobile: 07540 758555
Email: john.hambrook@playforce.co.uk
Web: www.playforce.co.uk



This e-mail and any attachments are sent for the personal attention of the addressee. Although you may be the named recipient it may become apparent that this e-mail and its contents are not intended for you and an addressing error has been made. This e-mail may contain information that is legally privileged and exempt from disclosure. If you have received this e-mail in error, please advise us immediately and delete this e-mail and any attachments from your computer system. TCL Group Head Office: TCL House (Registered Office), 7 Outrams Wharf, Little Eaton, Derbyshire DE21 5EG. T.C.L. Holdings (Parent) Limited, Registered in England and Wales 08976887. The presence of this footnote confirms that this e-mail has been automatically checked by TCL Group for the presence of computer viruses prior to being sent, however, no guarantee is given or implied that this e-mail is virus free upon delivery. **Please consider the environment. Please don't print this e-mail unless you really need to.**

On 15 Jul 2020 09:19, Hilary Workman <parishclerk@wickhambrook.org.uk> wrote:

[This email originated externally. Remember, think before you click.]

Hi John, many thanks for this, would it include new gateposts? Can you recommend any companies for fencing the remainder of the park?

Hilary Workman

Clerk & RFO for Wickhambrook Parish Council

Tel: 07508 039810

E-mail: parishclerk@wickhambrook.org.uk - Please note the new address

Website: <https://wickhambrook.org/parish-council/#parish-council-contact>

My normal working days are Monday, Wednesday and Thursday.

Confidentiality and Privilege: This email and its attachments are intended for the above named only and may be confidential. If they have come to you in error you must take no action based on them, nor must you copy or show them to anyone; please reply to this email and highlight the error. Click here to view our [privacy notice](#).

Security Warning and Viruses: Please note that this email has been created in the knowledge that Internet email is not a 100% secure communications medium. We advise that you understand and accept this lack of security when emailing us. Although we have taken steps to ensure that this email and attachments are free from any virus, we advise that in keeping with good computing practice the recipient should ensure they are actually virus free.

From: John Hambrook <john.hambrook@playforce.co.uk>

Sent: 14 July 2020 15:49

To: Hilary Workman <parishclerk@wickhambrook.org.uk>

Subject: RE: Playforce - Bury Road Play Area

Good Afternoon Hilary,

I hope that you are well?

Apologies for the delay in responding to your request. Funnily enough we had encountered some issues with the self-closing gates we use and have just agreed on a better product

We are able to supply and install a 1.2m wide premier sprung self closing gate - £783.60 + VAT, if you would like us to dig out and remove the existing gate will be £175.00 + VAT.

I hope that this will be of interest to you.

Kind Regards

John

John Hambrook

Sales Manager

Playforce, 1 Pegasus Way, Bowerhill Industrial Estate, Melksham, Wiltshire, SN12 6TR

Tel: 01225 792660

Mobile: 07540 758555

Email: john.hambrook@playforce.co.uk

Web: www.playforce.co.uk



This e-mail and any attachments are sent for the personal attention of the addressee. Although you may be the named recipient it may become apparent that this e-mail and its contents are not intended for you and an addressing error has been made. This e-mail may contain information that is legally privileged and exempt from disclosure. If you have received this e-mail in error, please advise us immediately and delete this e-mail and any attachments from your computer system. TCL Group Head Office: TCL House (Registered Office), 7 Outrams Wharf, Little Eaton, Derbyshire DE21 5EG. T.C.L. Holdings (Parent) Limited, Registered in England and Wales 08976887. The presence of this footnote confirms that this e-mail has been automatically checked by TCL Group for the presence of

computer viruses prior to being sent, however, no guarantee is given or implied that this e-mail is virus free upon delivery.
Please consider the environment. Please don't print this e-mail unless you really need to.

From: Hilary Workman <parishclerk@wickhambrook.org.uk>

Sent: 25 June 2020 14:09

To: John Hambrook <john.hambrook@playforce.co.uk>

Subject: RE: Playforce - Bury Road Play Area

[This email originated externally. Remember, think before you click.]

Hi John, just out of interest, do you ever fence in projects that you work on – we are having trouble with a self closing gate and one thought was whether playforce could quote for this (either fitted on its own, or as part of new fencing all around the play area.