

## Multi-Use Games Area

### Current Situation:

At its September meeting the parish council:

1. approved the cost of:
  - i. Removal and disposal of a basket ball hoop at Ground level£ £ 112.50
  - ii. Undertake repairs to damaged tarmac area £ 654.37
  - iii. Supply and install Green Bow Top fencing to a height of 1.2m £4269.80
  - iv. Delivery £ 112.50

a total cost of £5249.22 plus VAT, work to be undertaken by Playforce, and approved the transfer of £5,250 from earmarked reserves (Teen Project Replacement) to General Reserves (Report [WPC.21.09.10](#) & Min. 21.09.18 refer). A purchase order has been issued and the initial indication was that work to repair the surface and install the fencing would be completed by year end.

Additionally, the parish council agreed that it supported the Estate’s Committee’s proposal to:

1. research and consult on the development of a new MUGA; and
2. research, consult on and apply for grant funding to re-purpose the old MUGA space for:
  - low level cardiovascular equipment, with no requirement to re-surface the existing tarmac;

### Redevelopment of old MUGA for outdoor fitness equipment

There are a range of options for outdoor fitness stations which could be sited within the old MUGA space.

The parish council has established that the space should be used for low-level (below 600mm) cardiovascular equipment which therefore requires no safety surfacing beneath it. The equipment conforms to EN16630 specification (this is the safety standard for outdoor gym equipment). Additionally, a Gym Station, designed for body weight exercises, dips, pull ups, could be provided outside the former MUGA space, with Grass Matting. Indicative Quotes have been sought on the basis of this, (attached as **Appendix A**), and are summarised below, representing low, mid range and higher cost:

| Provider  | Equipment  | Cost  |
|-----------|--|---|
| Playforce | Adult Activ8 Outdoor Gym Multi-Unit<br>Adult Space saver Outdoor Gym Multi-Unit<br>Timber Gym Station  | project discounted to £14,350.78 (from £15,708.14) plus VAT.  |
| Proludic  | Proludic Sport Street Workout<br>Elliptical Trainer<br>Spinning Bicycle<br>Hydraulic Squat<br>Pendulum and Twister<br>Shoulder Press<br>Hand cycle | £24,771.69<br>Preliminaries have been included within your quotation, these equate to site setup, site storage, unloading of equipment, site welfare, heras fencing & |

Hilary Workman  
Clerk & RFO  
September 2021

## WPC.EC.21.10.03 – Multi-Use Games Area

| Provider | Equipment   | Cost   |
|----------|---|--|
|          | Proludic Sports App<br>Thermo plastic Graphics to create integrated workout<br>Safer surfacing<br>Prelims & Post installation inspection                  | signage and skips (this can also include supervision where necessary).   |
| Kompan   | 2 x suspension/combi trainers<br>Sport bike, Cross Trainer, Arm bike, Balance Board, Balance Station, Bench<br>Would accommodate 9 on low level equipment | £51,221.50 plus VAT<br>Includes installation & delivery.<br>Storage Container, site welfare, skip and heras fencing, to be provided by the client, however, KOMPAN can provide a quotation upon request.<br><b>Total</b> |

All quotes would be likely to be subject to some change based on changes to prices of raw materials and the period of time elapsing between indicative quotes and a final decision on provider based on secured grant funding.

There is funding for the Teen project replacement in earmarked reserves (£7,250 after funding of new bow top fencing to enclose the space) which could form the basis of seed funding for a larger grant application. It is suggested that some of this seed funding be set aside for part funding of any necessary new/replacement equipment in the Skate Park.

The mid range option, Proludic, includes its Users sports app to be used in conjunction with all Proludic gym and sports equipment. The app provides free exercise guides and allows users to track their workouts, as well as engaging with the local community and keeping motivation levels high. It also provides nearest parks on Google maps, recommended exercises and have helpful videos, tips for everyone that uses it. It will enable users to feel comfortable using the equipment.

The equipment options chosen allow users to increase resistance as they become fitter, and are also suitable for an older age range, and individuals with restricted mobility.

### **Action:**

The committee is asked to identify a preferred option and reasons to underpin a consultation with the parish based on a combination of:

- low level cardiovascular equipment, with no requirement to re-surface the existing tarmac; and
- An additional Timber Gym Station, which could be sited just outside of the fenced area.

Which would include an explanation of approximate costs and the implications of moving to individual equipment stations.

### **Reports:**

[WPC.EC.21.10.03](#)  
[WPC.EC.21.08.05](#)  
[WPC.21.09.10](#)

### **Minutes:**

21.10.10  
 21.09.18  
 EC.21.08.12

Hilary Workman  
 Clerk & RFO  
 September 2021



Hilary Workman  
Wickhambrook Parish Council  
123 York Rd  
Bury Saint Edmunds  
Suffolk  
IP33 3EG

20<sup>th</sup> September 2021

Ref: 133478JH

Dear Hilary,

**Re: Supply & Installation of outdoor gym equipment and bow top fencing**

Firstly, many thanks for taking the time to meet with me recently to discuss the potential new exciting outdoor project at your memorial open space.

Following our discussions, I am pleased to attach the quotation to supply and install a new outdoor gym equipment area to include cardiovascular equipment onto the existing tarmac area, enclosed with additional green bow top fencing. Then supply and installation of body weight gym equipment frame onto grass immediately outside of the tarmac area with safer grass mats safety surfacing.

**We are able to offer you with a free of charge funding service to take the stress out of your outdoor project. We require commitment that once we have secured the funds with you that the order is placed with Playforce (otherwise the service charge is applicable) then we will get cracking on raising the money for you. this service normally takes around 9-12 weeks.**

I hope you have found the above information will be of interest to you and if you require any additional information please do not hesitate to contact me directly.

With kindest regards,

**John Hambrook**

**National Sales Manager**

Tel: 07540 758555

Email: [John.Hambrook@playforce.co.uk](mailto:John.Hambrook@playforce.co.uk)

Web: [www.playforce.co.uk](http://www.playforce.co.uk)



**Enclosed for you**

- ✓ Your Quote

**Wickhambrook Parish Council**  
**Playforce Quotation Reference: 133478**

**20<sup>th</sup> September 2021**

[www.playforce.co.uk/important-info](http://www.playforce.co.uk/important-info)



|  |   |                  |
|--|---|------------------|
| 1. Delivery Cost   | £ | 820.98           |
| 2. Adult Activ8 Outdoor Gym Multi-Unit<br>PGYM110-A-NA   | £ | 6,503.47         |
| 3. Adult Spacesaver Outdoor Gym Multi-Unit<br>PGYM112-A-NA   | £ | 3,854.55         |
| 4. Timber Gym Station<br>PVR9040-A-S   | £ | 2,441.28         |
| 5. 30 x m <sup>2</sup> Safer Impact Grass Tiles - API advise 2m CFH when installed on to well kept grass<br>PSUR116-B-NA | £ | 2,272.80         |
| 6. Removal and Disposal of a basketball hoop At ground level.  | £ | 112.50           |
| 7. 37 x To supply and install Green Bow Top Fencing to a height of 1.2m high.  | £ | 4,269.80         |
| <b>Total</b>   | £ | <b>20,275.38</b> |
| <b>Total with Discount</b>   | £ | <b>19,200.78</b> |

Please note that all prices are subject to VAT, and quotations are valid for a period of 3 months from the date stated above.

### **Playground Inspections**

The British Standards for Playground Equipment and Surfacing, BSEN 1176 advises that all playground installations should be inspected by a competent person, and that the schedule should include routine daily/weekly inspections, operational and annual inspections.

We can take the hassle out of organising these for you with our Playforce Care inspection package. This covers the main annual inspection, three operational inspections and also includes on-site training for a member of your staff in undertaking weekly and monthly routine inspections. There are also discounts available for multiple sites in the same locality.

### **Wickhambrook Parish Council**

**Playforce Quotation Reference: 133478**

**20<sup>th</sup> September 2021**

[www.playforce.co.uk/important-info](http://www.playforce.co.uk/important-info)



**If you would like to include this inspection package, please indicate this when placing your order.**

|   |          |               |
|---|----------|---------------|
| * Annual Inspection Package – includes 1 x independent RPII-accredited annual inspection and report, 3 x quarterly operational inspections and on-site training for a member of your team | £        | 525.00        |
| <b>Total</b>  | <b>£</b> | <b>525.00</b> |

Please note that all prices are subject to VAT, and quotations are valid for a period of 3 months from the date stated above.

**Wickhambrook Parish Council**  
**Playforce Quotation Reference: 133478**

**20<sup>th</sup> September 2021**

[www.playforce.co.uk/important-info](http://www.playforce.co.uk/important-info)





The Playforce Design & Build and Playforce Sale of Goods terms and conditions available at [www.playforce.co.uk/important-info](http://www.playforce.co.uk/important-info) ("Terms and Conditions") shall apply to any orders that you may place with us and that order is made subject to those Terms and Conditions. By placing an order with us for goods and/ or services, you confirm that you have read and agree to the Terms and Conditions. In particular, please ensure that you read and agree to clause 12 of those Terms and Conditions which contains limits on our liability. Please note, all deposits are non-refundable.

All plans, quotations and correspondence between Playforce and the addressee are to remain strictly confidential between those parties only. Our customers value our uniquely creative designs, which are one of the qualities that set us apart from the competition and aid us in achieving best value!

All of our play equipment and safer surfacing conforms to the British and European Playground Safety Standards BS EN 1176 and 1177.

Please note that line markings and wetpour surfacing are weather dependent and as a result they may not be completed at the same time as the equipment installation. In this event, we may invoice the individual elements separately. When this is done, we will expect payment of each separate invoice in accordance with our terms and conditions. Wetpour surfacing colours can be affected by UV light at the time of installation. This will only be a temporary colour change, before the surfacing returns to its intended vibrant colour.

Tarmac surface skims are installed onto existing surfaces with the understanding that Playforce Ltd will not be held responsible for future repairs resulting from weed growth damaging the tarmac surface.

Playforce recommends the installation of kerb edging when installing wetpour surfacing onto tarmac / concrete and other hard surfaces. This type of edging detail provides a suitably firm fixing point for the surface and protects the surrounding hard surface from future cracking or failure. Chased edges can be provided but Playforce does not accept responsibility for any future repairs to the tarmac / concrete / hard surface or wetpour resulting from the expansion and contraction forces exerted by the surfacing.

Softbond mulch is frequently specified for installation onto existing grassed areas. Whilst we take care to ensure the suitability of the ground conditions at the time of specifying the product, there can be occasions when the ground beneath the softbond mulch, over a period of time, can move, causing the softbond mulch to sink. For this reason, Playforce advises the laying of an MOT Type 1 base before laying softbond mulch. Playforce therefore does not cover the costs of repairing these areas under warranty should the MOT option not be chosen.

Please note that we are unable to offer a warranty on wetpour repairs or surface skims with regards to the bond to an existing edge or existing surfaces. We would not recommend patch repairs, especially along edges as a suitable long-term solution.

The customer / client is reminded that it is their responsibility to ensure grassed areas are regularly cut and maintained to a height not exceeding 50mm, prior to the installation of any surfacing that may have been ordered. Failure to do so will incur costs for delays; any aborted visits or any other cost interrupting planned work.

We recommend that all existing court markings are removed before laying new line markings. Please note that removal of line markings come at an additional cost and this is not included with new line markings unless included specifically in your quotation. Failure to remove line markings before laying new ones will mean we are unable to offer a warranty on the new thermoplastics. We are also unable to offer a warranty for laying line markings over excavated or joined tarmac.

**To place your order, either send an e-mail to [John.Hambrook@playforce.co.uk](mailto:John.Hambrook@playforce.co.uk), stating your quote reference number (as on the top of this quote) and the value that you approve, or sign and date below and fax, email or post the confirmation back to us.**

**I agree and accept the above quotation from Playforce Ltd reference number 131694 dated 2 February 2021 to the value of £\_\_\_\_\_.**

**Signature:**

**Print:**

**Position:**

**Wickhambrook Parish Council**

**Playforce Quotation Reference: 133478**

**20<sup>th</sup> September 2021**

[www.playforce.co.uk/important-info](http://www.playforce.co.uk/important-info)

**playforce**



## **Funding Help Agreement**

**I agree and accept to work with Playforce Ltd and their funding partner to obtain funding for XXX project. Should we be successful in the application of funds and wish to seek an alternative use, or no longer want to proceed with the project or wish to find an alternative supplier of XXX project, we will be responsible for paying Playforce Ltd the costs of the application for bid writing and funding services totalling XXX.**

**If we are successful in the application and proceed as planned with Playforce Ltd there will be no cost. An unsuccessful bid will also result in no cost.**

**Signature:**

**Print:**

**Position:**

**Wickhambrook Parish Council**

**Playforce Quotation Reference: 133478**

**20<sup>th</sup> September 2021**

[www.playforce.co.uk/important-info](http://www.playforce.co.uk/important-info)







CLIMBOO WD1466

PLAYGROUND EQUIPMENT



| Device Specifications              |             |
|------------------------------------|-------------|
| Safety zone                        | 25,30 m     |
| Length                             | 2,32 m      |
| Width                              | 1,58 m      |
| Total height                       | 2,00 m      |
| Free fall height                   | 1,90 m      |
| Age range                          | 7-16 years  |
| In accordance w/ EN standards      | 1176-1:2017 |
| Weight of the heaviest part [kg]   | 11          |
| Dimension of the biggest part [cm] | 9x9x189     |
| Availability of spare parts        | Yes         |

Minimal space

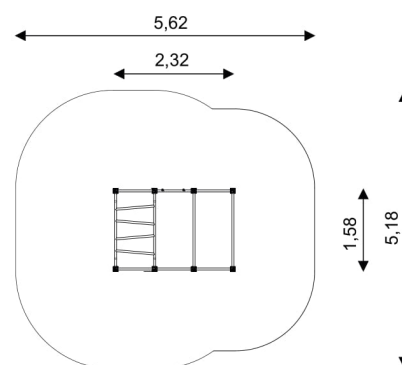

**Material Specification**

- 90x90 mm main construction made of impregnated, laminated wood of pine;
- Top of the construction is secured with polyethylene caps to protect the wood surface from atmospheric conditions;
- Metal anchors are made of hot dip galvanized steel, protecting the wood from direct contact with the ground to prevent rot and extending the product's life;
- Steel ropes braided with PP, connected by durable plastic elements;
- Stainless steel screws or screws covered with plastic caps;
- No sharp edges or chinks that would pose a danger of jamming the head, fingers or any other body parts;
- Stainless steel bars;

**Additional comments**

- The equipment is certified by an accrediting organization or by certificate of conformity;
- Depth of foundations on a flat surface: 80/70/60 cm;
- The equipment is designed for public playgrounds;The equipment render is of an illustrative nature and shows only the general specification of the equipment, but not its actual appearance. The colours may differ from those demonstrated on render.

**Surfaces**

Due to the free fall height of the equipment, the EN 1176-1:2017 standard allows the following surfaces: sand with minimal layer thickness of 30 cm (A,C), synthetic material approved for free fall of 1,90 m (A,B,C)





Hilary Workman  
Wickhambrook Parish Council  
6 Coltsfoot Close  
Wickhambrook  
Newmarket  
Suffolk  
CB8 8UP

16 November 2021

Dear Hilary,

Thank you for allowing us the opportunity to quote for Memorial Play Area - Cemetery Road - Wickhambrook.

Our aim at Proludic is to capture the imagination of every visitor to our play areas through inventive designs, creative ideas on inclusive play and stimulating products. We design our play areas to incorporate all these aspects whilst ensuring we achieve compliance with the relevant legislations.

We offer a full service including advice, design, contract management and a dedicated after sales service which is unmatched in this industry. We pride ourselves on our offering of complete solution from start to finish of your project.

We will contact you within two weeks to see how we can help further with your project. However if you have any queries regarding this quote or any part of our service in the meantime please do not hesitate to contact me on 07881 917 018.

Yours sincerely

Kiran Chouhan  
Area Sales Manager

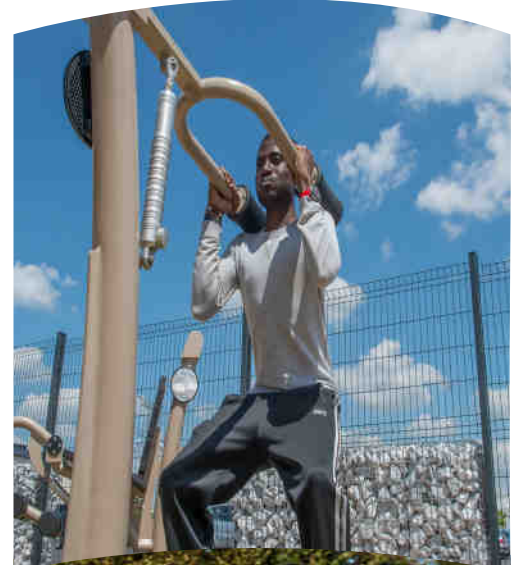





## Innovators in Sport and Fitness



- June 2002**  
Proludic Ltd established in the UK
- June 2003**  
Launch of the Proludic Sport which attains ISO 9001
- March 2004**  
Proludic are the first manufacturer to introduce a dynamic sports range, winning the Janus De L'industrie award for design excellence, economic value and ethical/environmental impact. Our vitality outdoor fitness range is also launched
- March 2008**  
Proludic redevelop the MUSA (Multi-use Sports Area) concept as an alternative to MUGA (Multi-use Games Area)
- November 2013**  
Proludic develop the social fitness packages
- May 2014**  
First SFZ (Social Fitness Zone) is installed in the UK at Market Harborough, Leicester
- June 2014**  
Urbanix is launched, the first hydraulic outdoor gym equipment
- October 2014**  
First Urbanix site is installed in Leatherhead, Surrey
- January 2015**  
Sport England launch 'This Girl Can' campaign aimed towards getting more women aged 14-40 involved in sport and physical activity
- May 2015**  
One of our SFZ's wins a highly commended award for community benefit at the East Midlands RICs Awards
- January 2016**  
Proludic introduce the Street Workout range
- August 2016**  
We created the Centre of Excellence for health & well-being in Knowsley - video case study available
- July 2017**  
Proludic Sports App is launched in the UK
- September 2017**  
Proludic collaborated with the Dame Kelly Holmes Trust, Canoeist and School of Calisthenics equipment
- September 2017**  
Proludic Pro App is launched allowing clients to access demographic and usage data
- September 2018**  
Proludic go into partnership with Rhino Ramps
- October 2020**  
200+ outdoor gyms, trim trails and calisthenics have been installed to date
- November 2020**  
Proludic are affiliated with World Street Workout and Calisthenics Federation
- January 2021**  
Proludic have 150+ products across eight ranges in their sport portfolio

## Your project team



**Rob Baker**  
Managing Director  
Play Industry Start Date: 1991

**Adam Dickerson**  
Commercial Manager  
Play Industry Start Date: 2004

**Kiran Chouhan**  
Area Manager  
Play Industry Start Date: 2014

**Dessia Wardle**  
Designer  
Play Industry Start Date: 2021

**Tracy Lehmann**  
Sales Coordinator  
Play Industry Start Date: 2009

## A typical work flow cycle

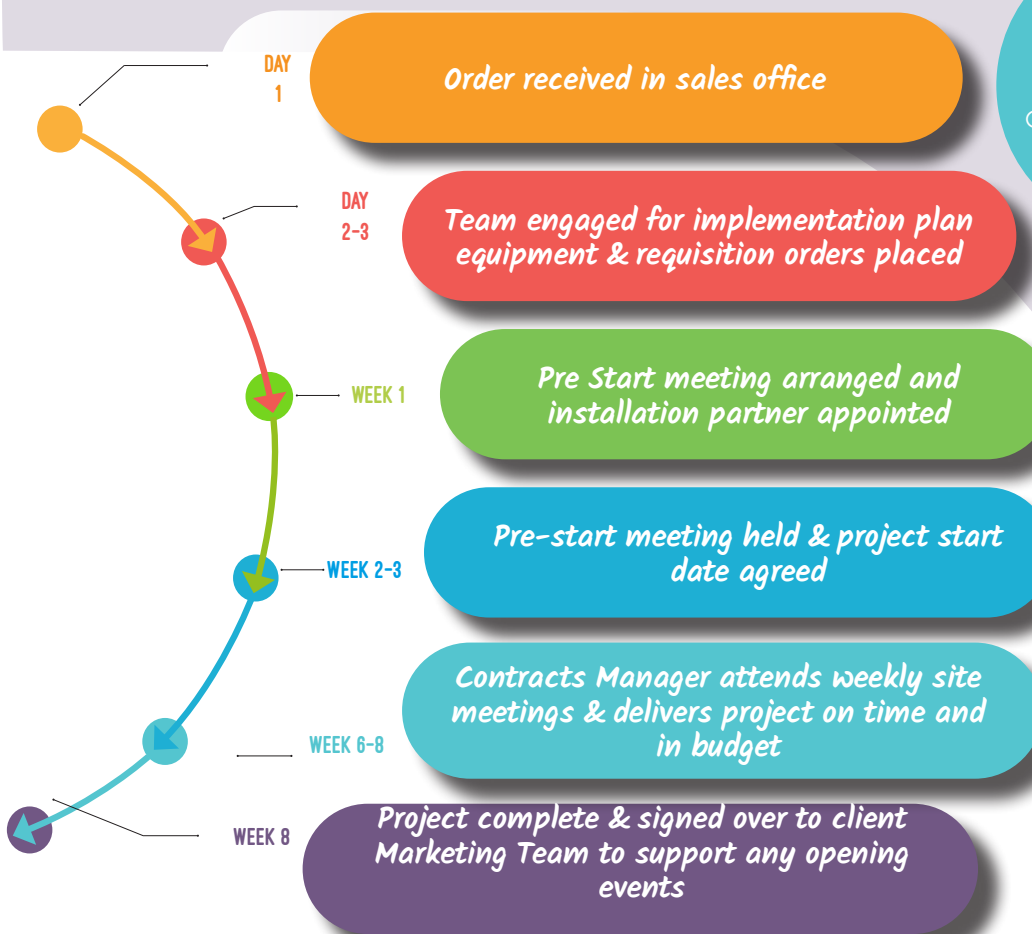

Locally based area sales managers, contractors & install teams

On site within 8 weeks on 92% of design & build projects

100+ years of industrial related experience



**Proludic - Committed to being your perfect partner**



## Your Aftersales/Service Team

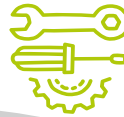

Helen Marsh  
Contracts &  
Aftersales Manager



Russell Dyer  
Contracts Manager



Miichelle Jones  
Contracts &  
Aftersales  
Coordinator



01159 823980  
aftersales@proludic.co.uk

### Measurable KPI's

Logging all calls  
within 24 hours  
and closing 85%  
of cases within 10  
working days

90% of product  
issues responded  
to within 3 working  
days

"I recently experienced some exceptional aftercare by the Aftersales and Maintenance Department at Proludic. They were very helpful and professional in delivering some maintenance on a number of our popular pieces of play equipment"

Mark Pickup - Parks Development  
Officer  
Hyndburn Borough Council



**Proludic - Committed to being your perfect partner**

## Aftersales Service

We provide one of the most efficient aftersales services in the industry thanks to our team that can be reached by telephone and email. Our team are supported by the most comprehensive aftersales service website available in the industry.

All our clients are provided with contact details for their dedicated Customer Service Advisor who will be happy to assist with any issues further to us leaving site. Clare can be contacted on 0115 9823980 or email: aftersales@proludic.co.uk

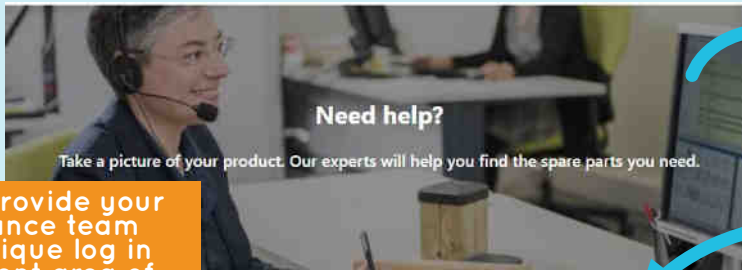

We will provide your maintenance team with a unique log in to the client area of our website; where you are able to report maintenance issues using the 'new' aftersales service that allows instant image uploads directly from site, along with a short description, enabling our team to identify replacement parts required.

**After-sales service**

**I need help**

Take a picture of your product. Our experts will help you find the spare parts you need.

**General view of the equipment or identification plate**

1. **Select a photo of your product**  
Images must be in JPG or PNG format

Select your file

Maximum upload size: 1MB

2. **Write a short description \***  
Please provide us with any information to help identify the product that has a problem. (year of purchase, product reference etc)

**Detail view of the part**

1. **Select a photo of your product**  
Images must be in JPG or PNG format

Select your file

Maximum upload size: 1MB

2. **Write a short description \***  
Please detail the problem encountered  
[here](#)

Proludic has the quickest and most challenging KPI's for spare parts in the UK and has a pledge that even discontinued products will have spare parts carried for a minimum of 10 years. This will help the lifetime management of the site and is a huge benefit. We offer a 2 year warranty on all parts.

### Availability of spares

We offer an extensive stock of spare parts within the UK. Our tiered system of availability of spare parts ensures that your maintenance needs are met. All of our fixings within our designs are common parts used throughout our ranges and are available from stock.

- List A (common spares 24 hours - 3 working days availability)
- List B (popular spares) 5-10 working days availability
- Non-List A/B availability on request

## Maintenance

For children, the pleasure of playing is all the greater if the equipment that is provided for their use is in good condition and checked regularly. This means that they can make the most of the facilities. The durability and safety of a playground depends to a great extent on the servicing and maintenance work carried out, together with the fact that the products have been designed in accordance with quality principles, as is the case with all PROLUDIC products.

### Safety Standards

Since the European safety standards were issued in 1998, the obligation met by the operating entity and the equipment supplier have been clearly defined in the form of the normative texts EN 1176-1 and EN 1176-7. The latter determines various checks to be made at specific intervals. These intervals are given for information purposes only; they must be adapted to suit the frequency of use and the site.

### Repairs

During the defects correction period we will respond to your issues within two hours; and we will advise you how we will solve the problem within 24 hours. We will also endeavour to utilise a Proludic Maintenance Engineer to replace the part.

#### Our Promise

90% of requests processed within 24 hours



We have invested heavily in our Customer Management System (Salesforce). Salesforce is a cloud based CRM system allowing the entire team instant access to all relevant information whether in the office, on site or from home if necessary. Salesforce enables us to focus on our relationship with individual clients, colleagues and suppliers. We are able to monitor and update all projects live together, ensuring that each piece of Proludic equipment has a full life-cycle history. As part of our monitoring of all Proludic equipment we are able to raise cases within Salesforce to log a warranty/guarantee issue.

The Salesforce logo, which consists of the word "salesforce" in a white, lowercase, sans-serif font inside a blue, cloud-like shape.

*Proludic - Committed to being your perfect partner*



# Proludic - Your perfect partner



## 25 YEARS

For all Urbanix Blade outdoor gym equipment aluminium & stainless hardware against structural failure & corrosion due to manufacturing defects



## 10 YEARS

For all Urbanix Blade outdoor equipment main posts, steel tubes and welding procedure against structural failure due to manufacturing defects

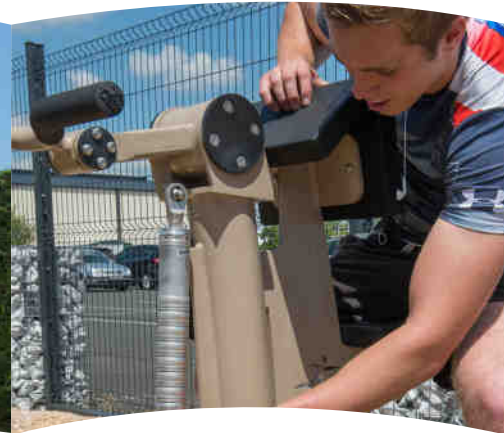

## 2 YEARS

For all Urbanix gym equipment in whole, hydraulic and moving systems, bearing, handles and cushions under normal conditions

For full details please contact a member of the proludic team

## Our Website

User friendly and easy to identify any parts of products

The screenshots show the Proludic website interface. The top navigation bar includes 'Company', 'Catalogues', 'Products', 'Services', 'Play area', 'After sales', 'Contact', and 'News'. A search bar is visible. The main content area features a 'PLAY' section with a sub-header 'A playground is also the development...' and a list of 'MULTI-PLAY EQUIPMENT' with prices ranging from 1800 to 142700. Below this, there are sections for 'MOVING EQUIPMENT' and 'TRADITIONAL EQUIPMENT'. A right-hand sidebar titled 'After-sales' lists services like 'Repair services', 'On-site maintenance', 'New parts', 'Disassembly services', 'Product advice', and 'Spares parts list'. At the bottom, there is a section for 'Owner's Manual' with a search form for order and customer numbers. A technical drawing for model 'J3961A' is shown, detailing impact area (0.45m x 8m²) and free space (3.15m), with references to EN 1176-1:2008 and EN 1176-5:2008.

Proludic - Committed to being your perfect partner

## Delivering Excellence

Proludic have been awarded several prestigious awards in the last 4 years which is testament to the innovation and quality of our products and projects

### Awards

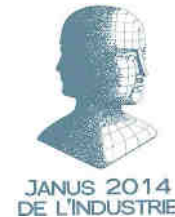

### Accreditations



### Our promise to you

“As active members of the Association of Play Industries (API), Proludic support the implementation of innovative and dynamic play. This must be done using high quality materials, by a skilled workforce and within EN standards to ensure that a safe and durable solution is delivered.

Proludic are an ISO 9001 approved manufacturer but our commitment to excellence extends far beyond this. In a bid to raise the bar to the highest possible level, Proludic also monitors and manages its subcontractor partners on; health and safety, communication and on-time delivery, as well as other key performance indicators to ensure a smooth and successful delivery is experienced from start to finish”.

**Rob Baker - Managing Director**

*Working with local contractors to deliver Excellence*

## What sets us apart



*1. Competitive on price but driven by design*



*2. Exceeding our customers needs*



*3. The innovators in our industry*



*4. Consultation & engagement*



*5. Funding direction and support*

## The Proludic Sports App - Users App

At Proludic we are passionate about providing facilities that will appeal to people of all levels of fitness - from beginners to athletes - allowing and encouraging all to work at their own pace. This inclusive approach inspires increased physical activity and encourages progression and improvement of physical health, confidence and wellbeing, regardless of the user's fitness or ability level.

To support this and to aid the usage of outdoor fitness equipment, Proludic have launched a Sports app to be used in conjunction with all Proludic gym and sports equipment. This app provides free exercise guides and allows users to track their workouts, as well as engaging with the local community and keeping motivation levels high. It's almost like having a personal trainer on site 24/7!

The App has been developed to enable users to simply and easily monitor and track their exercises on Proludic sports equipment. It will also provide nearest parks on Google maps, recommended exercises and have helpful videos, tips for everyone that uses it. It will enable users to feel comfortable using the equipment.

Users over the age of 18 will also have access to a community forum where you can share/challenge/chat and motivate your local friends and then see how you rank locally/nationally/Internationally. This is also great for local boot camps and personal trainers that will use the equipment. For all of our clients, it will serve as an aid to encourage more people in the community to get fit and use the equipment. The app also works in conjunction with Apple health helping the users with their daily step targets.

### MARKET LEADING MOBILE APPS



**PROLUDIC SPORT APP**

The Proludic Sport app is a digital workout partner to support the USERS throughout their workout experience.

**ALLOWS USERS TO:**

- Find the nearest gym in their area.
- Learn about the fitness equipment through demonstration videos.
- Create personal workouts tailored to their needs i.e. time, muscle group and fitness goals.
- Track their workouts.
- Connect with their community and interact with friends.
- Earn achievements and challenge others.



DOWNLOAD THE PROLUDIC SPORTS APP  
SCAN ME!

Download the Proludic Sports App



Sign in and create an account



Navigate the app to meet your workout requirements



SPINNING BICYCLE







**PROLUDIC SPORT PRO APP**

The Proludic Sports PRO app provides aggregated usage data on the performance of the fitness area for PROVIDERS.

**ALLOWS ORGANISATIONS AND LOCAL AUTHORITIES TO:**

- Download user and site specific equipment analytics at a glance to evidence and support investment.
- View gym statistics, including the number of users per machine.
- Examine aggregated statistics to keep track of multiple sites. Benchmark your location against national performances.
- See important demographics and usage - day, time, age, gender, activity, apple health and dwell time.
- Instantly send after sales and maintenance requests by simply uploading a photo and submitting.



## *Contents*

|   |   |
|---|---|
| <i>Site Plan &amp; Design</i>             | 1 |
| <i>Pricing Breakdown</i>                  | 2 |
| <i>Technical Datasheets</i>               | 3 |
| <i>Warranties &amp; Test Certificates</i> | 4 |
| <i>Case Studies</i>                       | 5 |
| <i>Terms &amp; Conditions</i>             | 6 |



*Appendices*



## Contents

|   |   |
|---|---|
| <i>Site Plan &amp; Design</i>             | 1 |
| <i>Pricing Breakdown</i>                  | 2 |
| <i>Technical Datasheets</i>               | 3 |
| <i>Warranties &amp; Test Certificates</i> | 4 |
| <i>Case Studies</i>                       | 5 |
| <i>Terms &amp; Conditions</i>             | 6 |



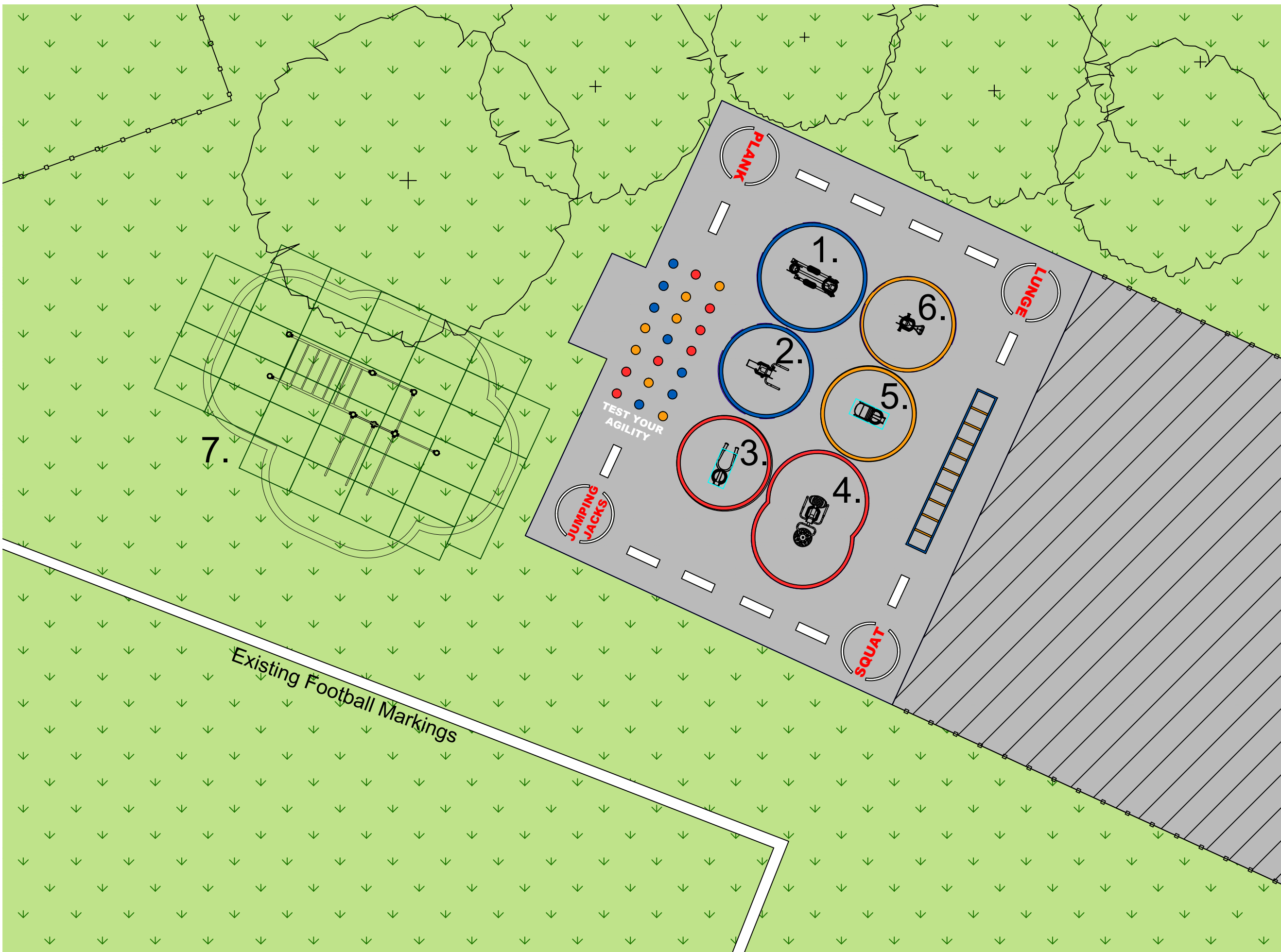

### ITEMS LIST

- Sport Equipment**
- |                             |                   |
|-----------------------------|-------------------|
| 1. Elliptical Trainer       | Ref: R37-UBX-203B |
| 2. Spinning Bike            | Ref: R37-UBX-289B |
| 3. Hydraulic Squat          | Ref: R37-UBX-217B |
| 4. Pendulum and Twister     | Ref: R37-UBX-232B |
| 5. Hydraulic Shoulder Press | Ref: R37-UBX-247B |
| 6. Recharging Hand Cycle    | Ref: R37-UBX-287C |
| 7. Metal Street Workout     | Ref: J5210A       |

**Safety Surfacing**  
Item 7 to be surfaced with 54m<sup>2</sup> EcoSmart Grassmat.

- Thermoplastic Graphics**  
Area to be surfaced with thermoplastic graphics, details as follow:
- 4No. White Circles with Red Text
  - 2No. Blue Rings, 2No. Orange Rings and 2No. Red Rings around Urbanix products
  - Blue Ladder with Orange Rungs
  - 7No. Blue Circles, 7No. Orange Circles, 7No. Red Circles with White Text
  - 12No. White Dash Markings

**Miscellaneous**  
Preliminaries  
Post Installation Inspection

*Due to the demand on the supply of our Urbanix products stock levels are subject to availability at the time of placing an order*

*Proposed Grassmat Safer surfacing is based on a fully established grass site (including a minimum of 150mm of good quality soil and turf).*

*Proposed Grassmat will follow the natural contours of the land.*

*Preliminaries have been included within your quotation, these equate to site setup, site storage, unloading of equipment, site welfare, heras fencing & signage and skips (this can also include supervision where necessary).*

**PRODUCT KEY**

|                        |                       |
|------------------------|-----------------------|
| Grass                  | Grassmat              |
| Thermoplastic Graphics | Existing Hardstanding |
| Existing Skate Park    | Existing Fencing      |
| Free Fall              | Free Space            |

# Memorial Play Area - Cemetery Road

Wickhambrook Parish Council

DATE: 12/11/2021 REF: 2111.31727(MemorialPlayArea\_WickhambrookParishCouncil)

REV: - DB: DW CB: PP SCALE: 1:100 @ A3



# Memorial Play Area

Proludic sport

14+ Years

17+ Users



Line Marking Trim Trail!

Over 2.5m High

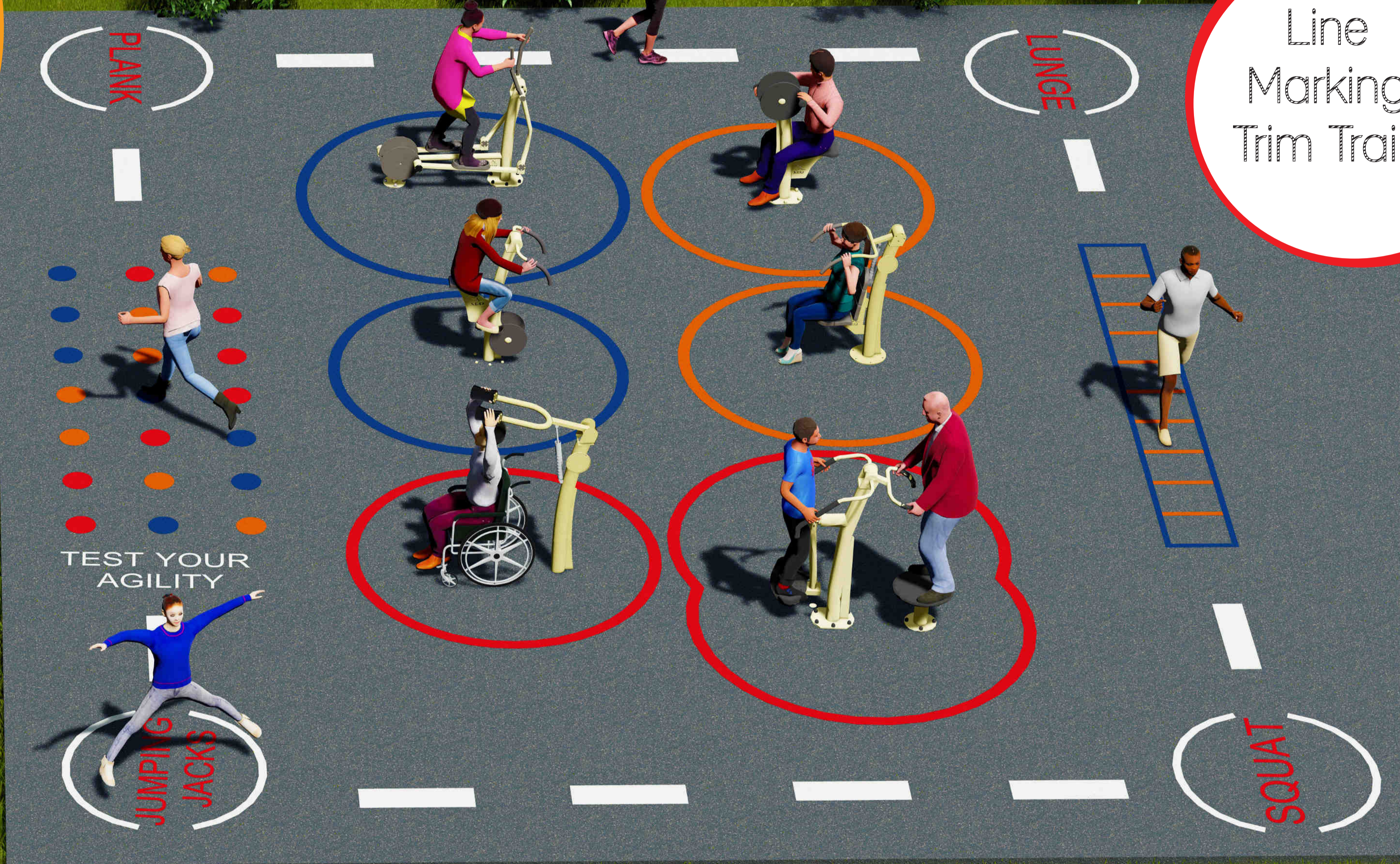

# Memorial Play Area

Proludic sport

14+ Years

17+ Users

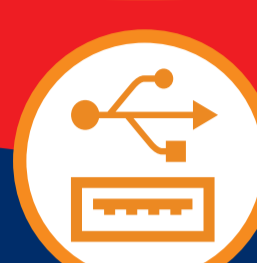

## Dip Bar

- ▶ Build your overall strength on the dip bars
- ▶ All muscles of the body can be developed through different exercises
- ▶ Try exercises like dips, I-sits and bicycle walks



## Horizontal Bar

- ▶ Use your upper body strength to pull up on the bars
- ▶ Requiring a lot more effort to pull up on the bars, it works on all your muscles simultaneously
- ▶ Try out exercises like knee ups, chin ups and leg raises

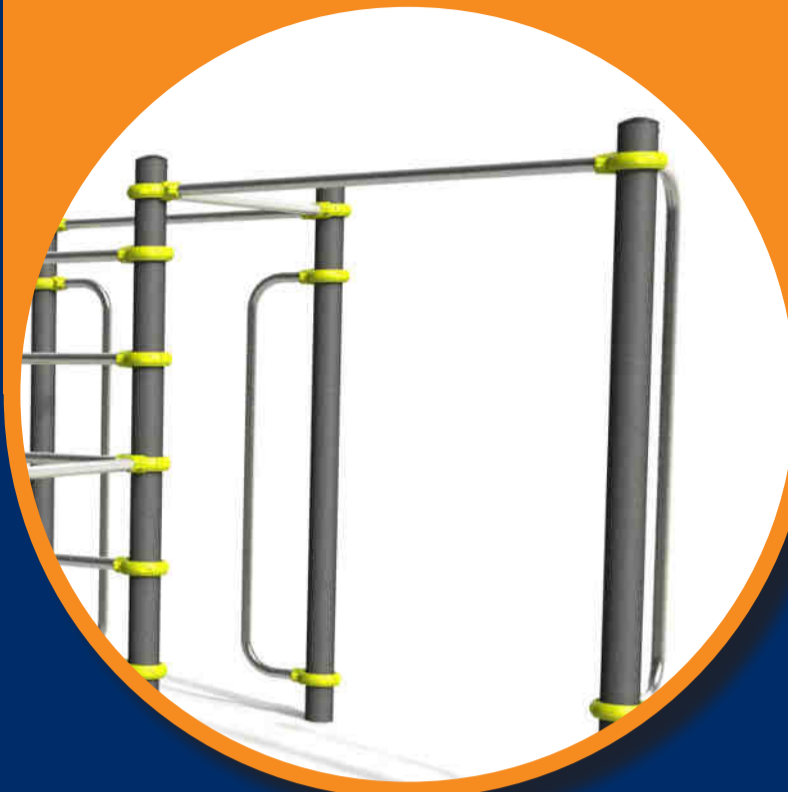

## Horizontal Ladder

- ▶ Strengthen and tone your arms and legs as you climb up and over the ladder
- ▶ The lower bars can be used for exercises such as toe taps, calve raises and hill climbs
- ▶ The horizontal ladder can be used for low impact warm up and cool down exercises



## Horizontal Ladder

- ▶ Build your upper body and core strength as you pull yourself up on the bars and traverse across
- ▶ All muscles of the body can be developed through different exercises
- ▶ Try exercises like pull ups, hanging leg raises and bar dips



## FEATURES & BENEFITS

|  |  |  |  |
|--|--|--|--|
|  | <b>Colour</b><br>Beige in colour – attracts the right age group for the product. Durable and resistant finish.             |  | <b>Signage</b><br>Clear concise signage – users know how to use the equipment safely and efficiently QR Code technology. |
|  | <b>Tested</b><br>all equipment conforms to EN 16630 regulations. no head, limb or finger traps on any equipment.           |  | <b>Tech</b><br>Clear and simple instructional videos are accessible via QR codes attached to equipment.                  |
|  | <b>Long Handles</b><br>Long handle grips – suits all ages and abilities.   |  | <b>Seating</b><br>Polysafe soft seats – ensure comfort, durability and usage all year around.                            |
|  | <b>Safe</b><br>Safestop piston with zero touch-points and internal stoppers. Prevents sudden drops & falls & finger traps. |  | <b>Resistance</b><br>8 levels of resistance ranging from 5kg–60kg allows progression to all ability levels.              |

Proludic Sports App

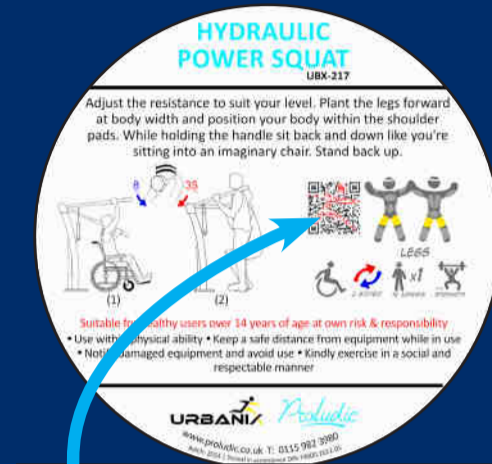

Scan the QR code on any piece of equipment to be linked to a video demonstrating the safe use of equipment



Download the Proludic Sports App

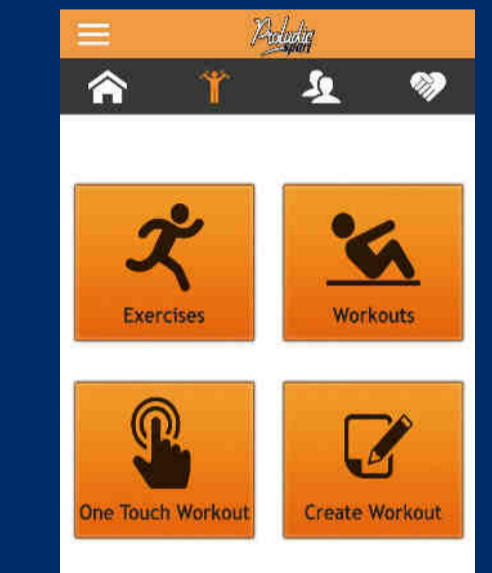

Navigate the app to meet your workout requirements



Sign in and create an account

## ABS STRENGTHENING EXERCISES

This abs exercise is really effective in strengthening the abdominal muscles. It helps to have a flat stomach and strengthen the core muscles that protect the spine.



## POSITION

Lie on your front, with back straight, face down.

## EXERCISE

Prop yourself up on your forearms and toes. Keep your legs straight and hips raised. Hold in your stomach muscles and tighten your perineum.

## CHALLENGE

4 to 5 times  
Hold for  
30 seconds  
each time



Do not arch your back. Hold in your stomach muscles

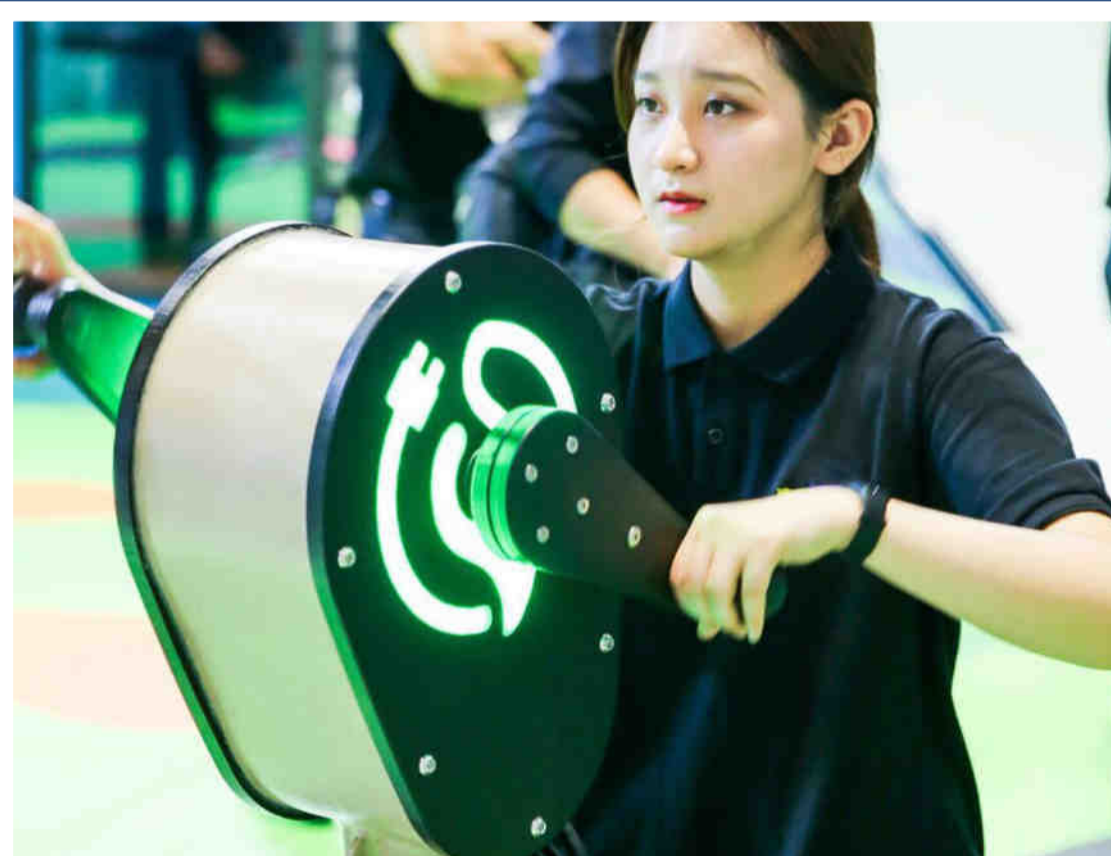

## UBX-287C Recharge Hand Cycle

- ▶ Focuses on the muscles in the arms, shoulders, chest and back
- ▶ Calorie burning
- ▶ Boosts fat loss
- ▶ Improves cardiovascular performance

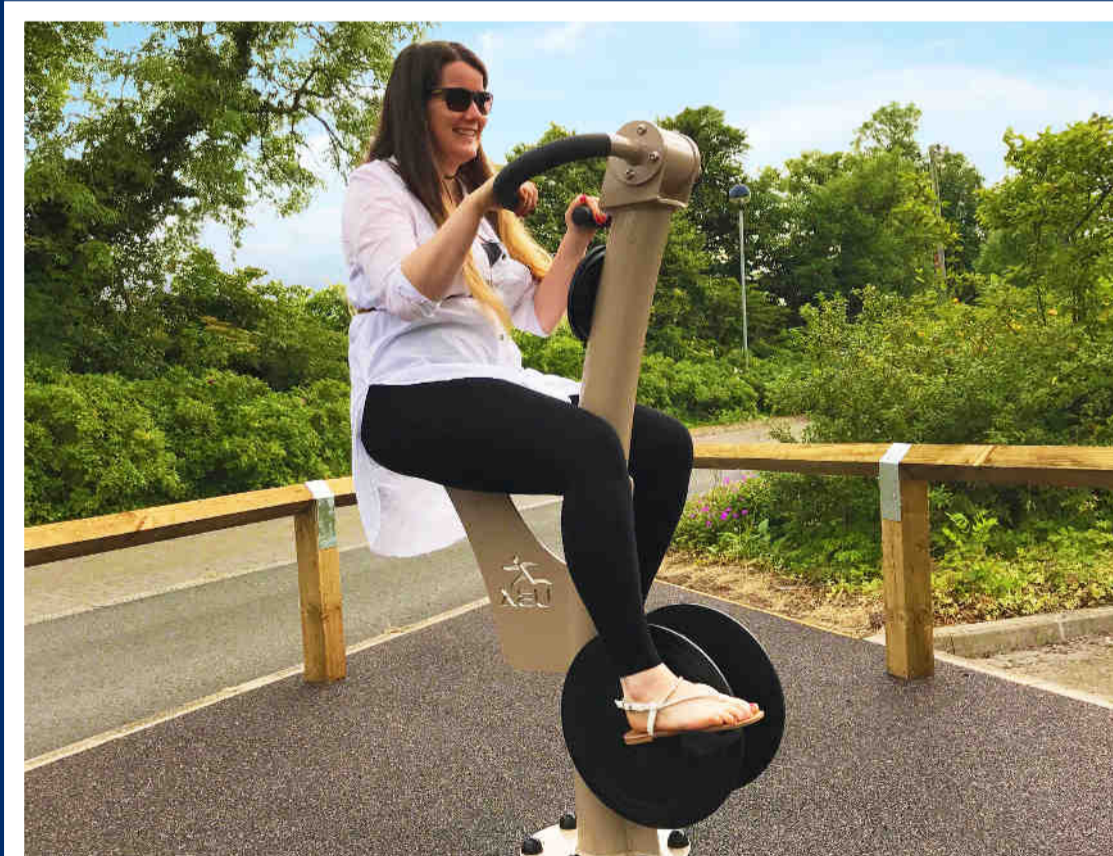

## UBX-289 Spinning Bike

- ▶ Focuses on the major muscles in the lower body
- ▶ Calorie burning
- ▶ Boosts fat loss
- ▶ Improves cardiovascular performance



## UBX-247 Shoulder Press

- ▶ Focuses on the major muscles in the upper body
- ▶ While the shoulder press focuses primarily on two portions of the deltoids, or shoulders, it also works a plethora of other muscles
- ▶ This exercise will also help stabilise muscles and movements that use your shoulders.

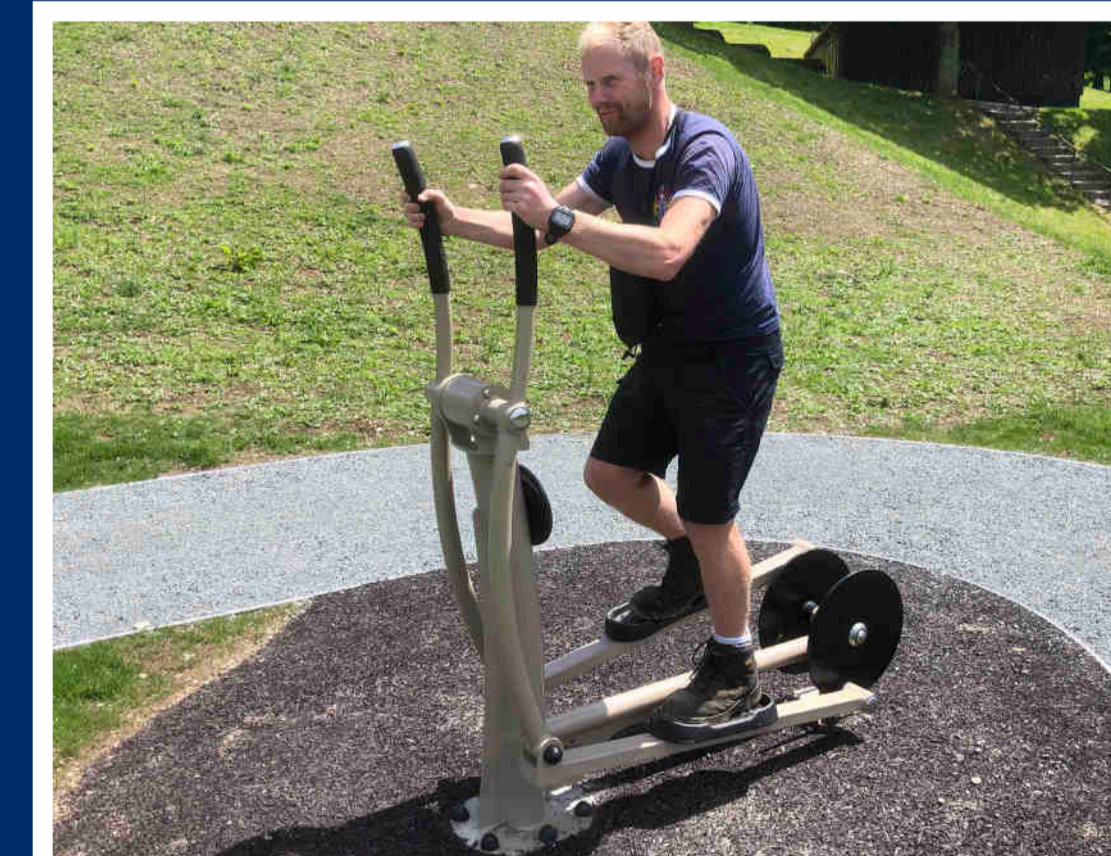

## UBX-203 Elliptical Trainer

- ▶ Focuses on the muscles in the arms, shoulders, chest and back
- ▶ Calorie burning
- ▶ Boosts fat loss
- ▶ Improves cardiovascular performance



## UBX-217 Hydraulic Squat

- ▶ The Hydraulic Squat Machine brings you a targeted workout for your legs, glutes and thigh muscles
- ▶ Its hydraulic system allows you to get on the machine and just go
- ▶ An easy to use very accessible machine



## UBX-232 Pendulum & Twister

- ▶ Multi activity unit allows two users to work out at once
- ▶ One activity requires the user to swing like a pendulum while working the leg muscles
- ▶ The other activity requires the user to twist in a gentle motion working the leg muscles and lower back area

## *Contents*



|   |   |
|---|---|
| <i>Site Plan &amp; Design</i>             | 1 |
| <i>Pricing Breakdown</i>                  | 2 |
| <i>Technical Datasheets</i>               | 3 |
| <i>Warranties &amp; Test Certificates</i> | 4 |
| <i>Case Studies</i>                       | 5 |
| <i>Terms &amp; Conditions</i>             | 6 |







*Pricing  
Breakdown*

Prepared for: Wickhambrook Parish Council  
 Our Reference: 2111.31727  
 Date: 16 November 2021

### Quotation for Memorial Play Area - Cemetery Road - Wickhambrook

| Qty                                   | Code          | Product Name  | Unit Price    | Total Line Price |
|---------------------------------------|---------------|---|---------------|------------------|
| <b>02. Proludic Sport</b>             |               |   |               |                  |
| 1                                     | J5210A        |  Metal Street Workout                | 5,345.64      | 5,345.64         |
| 1                                     | PJ5210A       | Installation of J5210A  | 931.00        | 931.00           |
|                                       |               |   | <b>Total:</b> | <b>£6,276.64</b> |
| <b>05. Partnership Play Equipment</b> |               |   |               |                  |
| 1                                     | R37-UBX-203B  |  Elliptical Trainer                | 1,268.00      | 1,268.00         |
| 1                                     | PR37-UBX-203B | Installation of R37-UBX-203B  | 263.90        | 263.90           |
| 1                                     | R37-UBX-289B  |  Proludic Urbanix Spinning Bicycle | 1,090.00      | 1,090.00         |
| 1                                     | PR37-UBX-289B | Installation of R37-UBX-289B Urbanix Spinning Bike  | 263.90        | 263.90           |

|   |   |               |   |               |                   |
|---|---|---------------|---|---------------|-------------------|
| 1 |    | R37-UBX-217B  | Proludic Urbanix Hydraulic Squat                  | 2,261.00      | 2,261.00          |
| 1 |   | PR37-UBX-217B | Installation of R37-UBX-217B Hydraulic Squat      | 263.90        | 263.90            |
| 1 |    | R37-UBX-232B  | Proludic Urbanix Pendulum and Twister             | 1,391.00      | 1,391.00          |
| 1 |   | PR37-UBX-232B | Installation of R37-UBX-232B Pendulum and Twister | 263.90        | 263.90            |
| 1 |  | R37-UBX-247B  | Proludic Urbanix Hydraulic Shoulder Press         | 2,831.00      | 2,831.00          |
| 1 |   | PR37-UBX-247B | Installation of R37-UBX-247B                      | 263.90        | 263.90            |
| 1 |  | R37-UBX-287C  | Urbanix Recharging Hand Cycle                     | 1,975.00      | 1,975.00          |
| 1 |   | PR37-UBX-287C | Installation of R37-UBX-287C                      | 264.00        | 264.00            |
|   |   |               |   | <b>Total:</b> | <b>£12,399.50</b> |

**09. Safer Surfacing**

|    |                  |  |               |                  |
|----|------------------|--|---------------|------------------|
| 54 | UKS1016          | EcoSmart Grass mat<br>3m CFH (per m <sup>2</sup> ) | 31.00         | 1,674.00         |
| 1  | UKANCLINEMARKING | Thermoplastic Graphics (See CAD for details)       | 1,267.00      | 1,267.00         |
|    |                  |  | <b>Total:</b> | <b>£2,941.00</b> |

**11. Miscellaneous Items**

|   |         |                              |               |                  |
|---|---------|------------------------------|---------------|------------------|
| 1 | UKA1003 | Prelims                      | 1,250.00      | 1,250.00         |
| 1 | UKA1100 | Post Installation Inspection | 450.00        | 450.00           |
|   |         |                              | <b>Total:</b> | <b>£1,700.00</b> |

---

Delivery Charge: £1,454.55

**Total Quote Amount: £24,771.69**

Due to the demand on the supply of our Urbanix products stock levels are subject to availability at the time of placing an order

Proposed Grassmat Safer surfacing is based on a fully established grass site (including a minimum of 150mm of good quality soil and turf).

Proposed Grassmat will follow the natural contours of the land.

Preliminaries have been included within your quotation, these equate to site setup, site storage, unloading of equipment, site welfare, heras fencing & signage and skips (this can also include supervision where necessary).

This quote is valid until 23/12/2021  
Please note all prices quoted are excluding VAT



## Contents

|                                |          |
|--------------------------------|----------|
| Site Plan & Design             | 1        |
| Pricing Breakdown              | 2        |
| <i>Technical Datasheets</i>    | <i>3</i> |
| Warranties & Test Certificates | 4        |
| Case Studies                   | 5        |
| Terms & Conditions             | 6        |



Technical  
Datasheets



14+



10



2,1m



1 = 5,15m 2 = 3,17m 3 = 2,52m

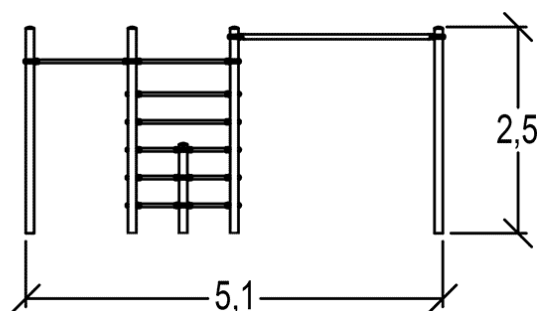
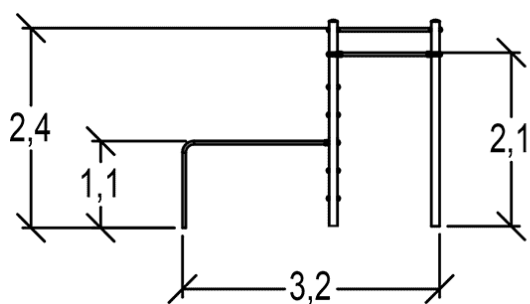

Play value : 4

hanging



x2

climbing



x2

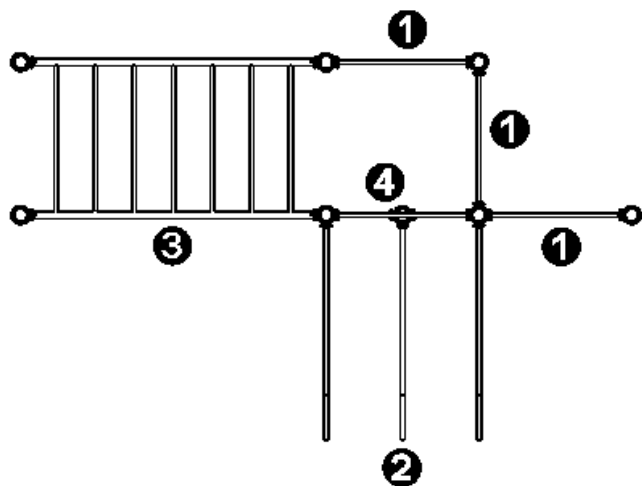

- ① Horizontal bar L:1.25m
- ② Parallel bar
- ③ Horizontal ladder
- ④ Wall bars

## Installation of equipment

Impact area =

- Impact area
- Free space

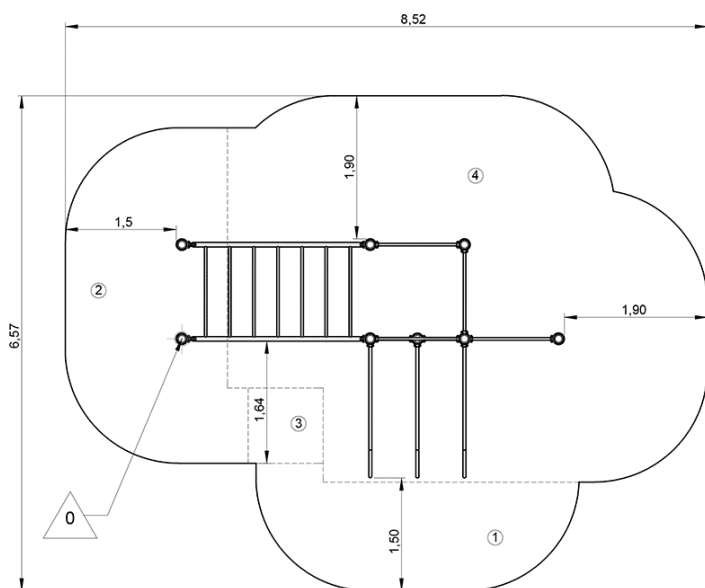

| 1 | 1m   | 5,5m <sup>2</sup>  |
|---|------|--------------------|
| 2 | 1,4m | 9m <sup>2</sup>    |
| 3 | 1,7m | 1m <sup>2</sup>    |
| 4 | 2,1m | 27,5m <sup>2</sup> |



2



4:h0



1.6m<sup>3</sup>



43m<sup>2</sup>



289kg



28kg

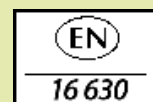

0000-00-00



14+



1



0,35m



1 = 1,42m 2 = 0,55m 3 = 1,66m



**MUSCULAR STIMULATION**



**MOVEMENTS**

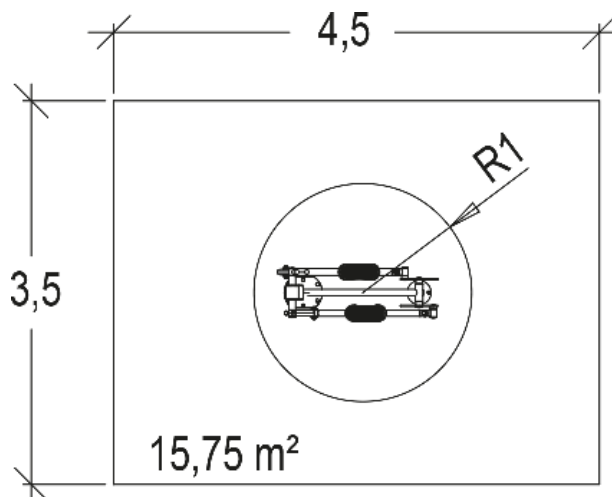
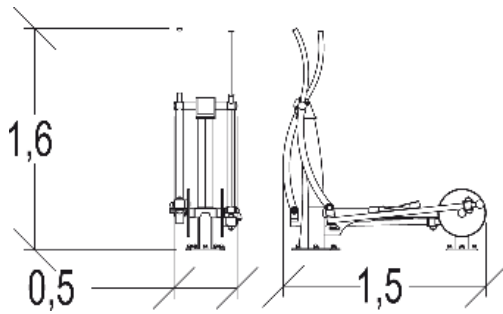
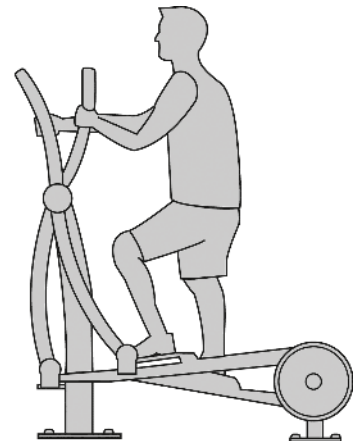

**CERTIFICATIONS**

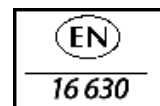



14+



1



0m



1 = 1,18m 2 = 0,45m 3 = 1,45m



User controlled hydraulic piston

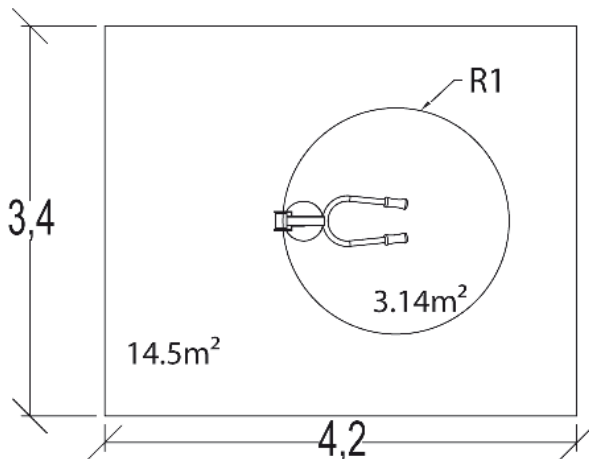
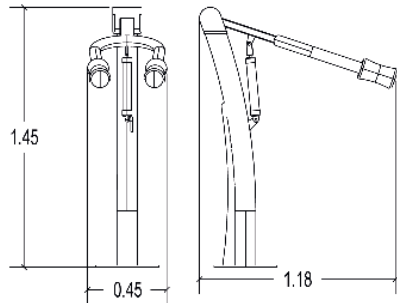

**MUSCULAR STIMULATION**

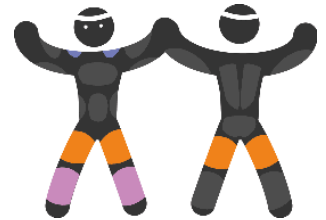

**MOVEMENTS**

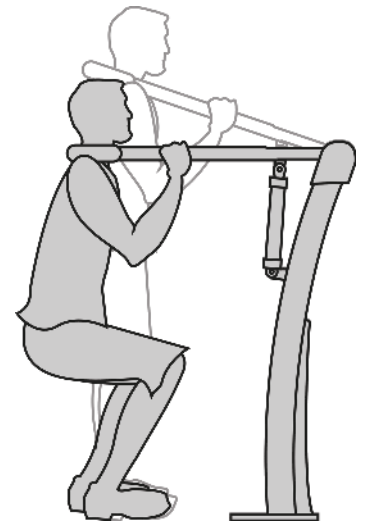

**CERTIFICATIONS**

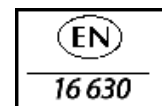



14+



2



0,5m



1 = 1,5m 2 = 0,6m 3 = 1,5m



### MUSCULAR STIMULATION



### MOVEMENTS

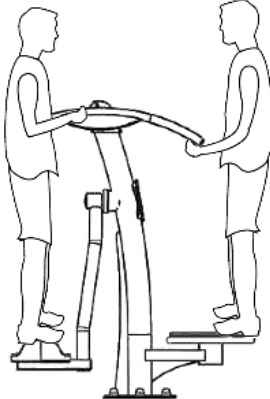

### CERTIFICATIONS

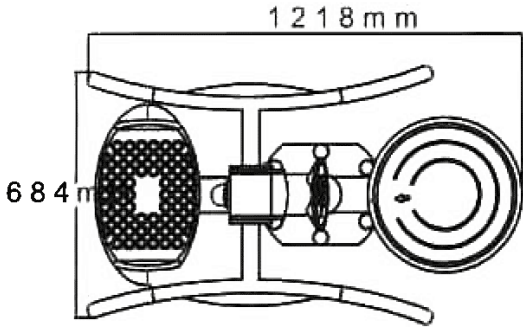
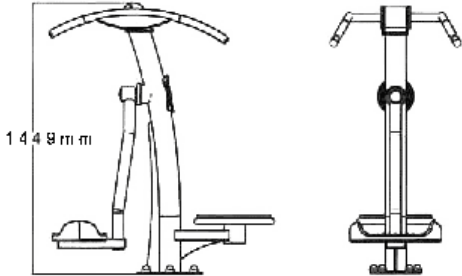
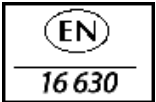



14+



1

0,5m



1 = 0,9m 2 = 0,8m 3 = 1,45m



User controlled hydraulic piston

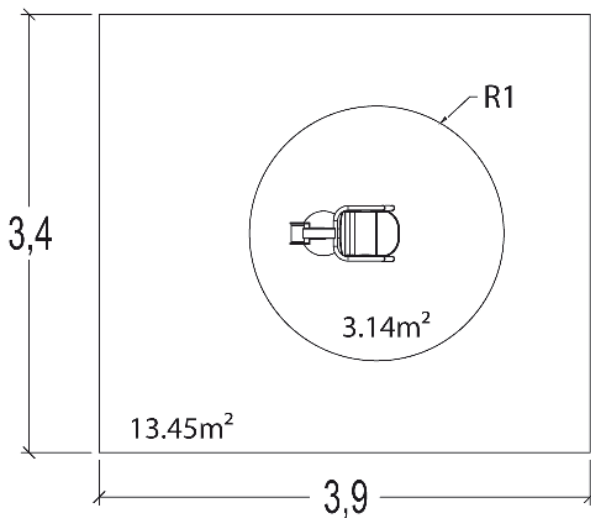
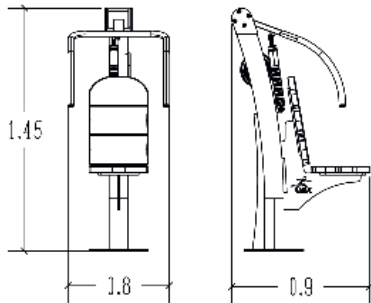

**MUSCULAR STIMULATION**

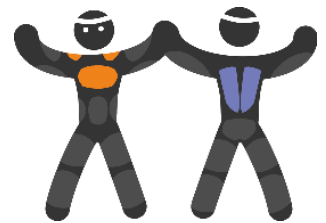

**MOVEMENTS**

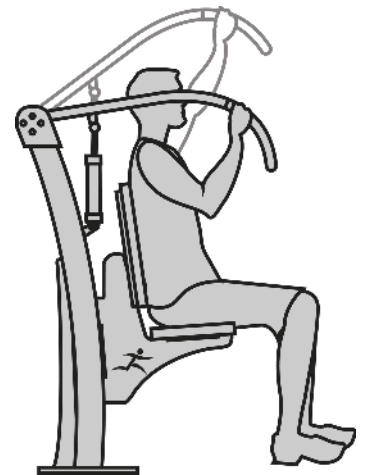

**CERTIFICATIONS**

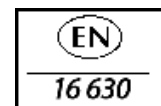



14+



1



0,5m



1 = 0,74m 2 = 0,5m 3 = 1,21m



### MUSCULAR STIMULATION



### MOVEMENTS

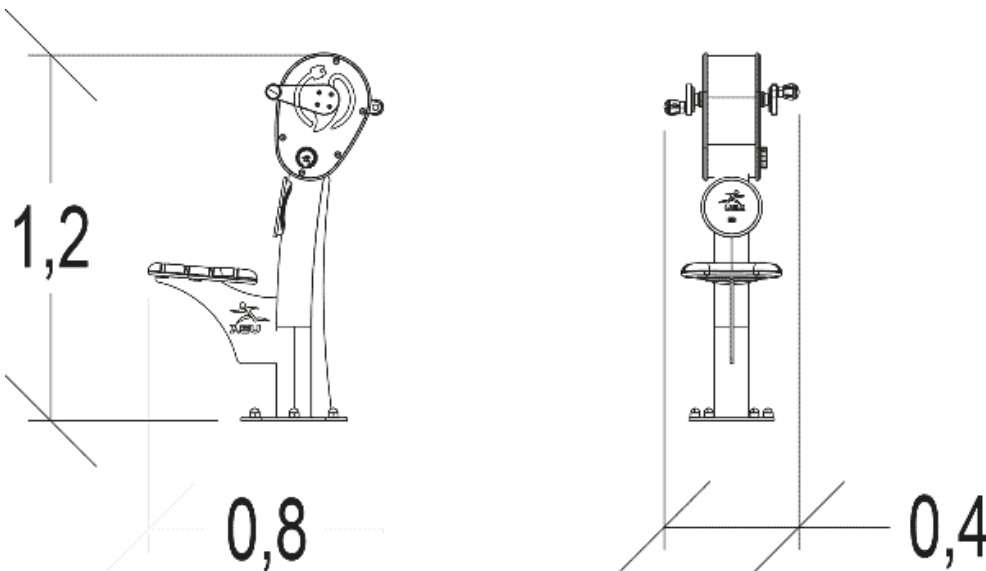
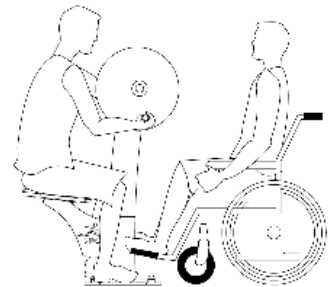

### CERTIFICATIONS

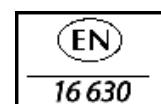





14+



1



0,85m



1 = 0,8m 2 = 0,6m 3 = 1,4m

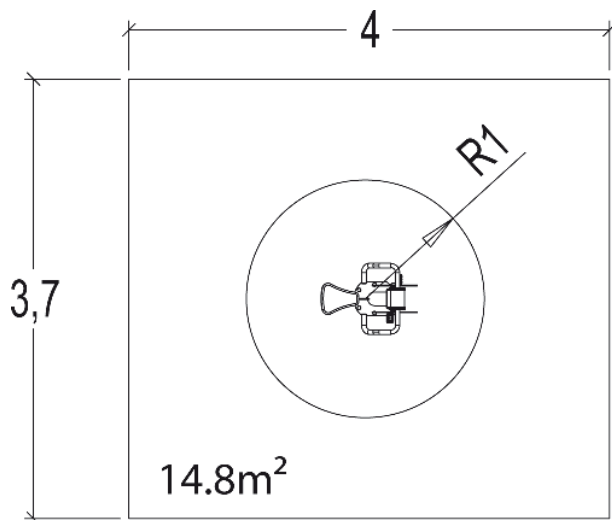
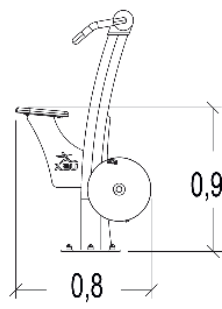
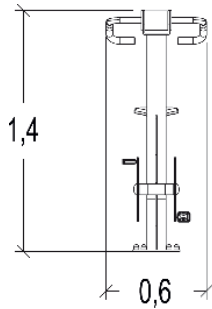

**MUSCULAR STIMULATION**



**MOVEMENTS**

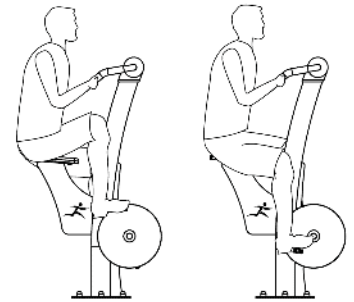

**CERTIFICATIONS**

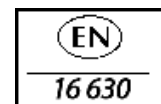

## Contents

|   |          |
|---|----------|
| Site Plan & Design                        | 1        |
| Pricing Breakdown                         | 2        |
| Technical Datasheets                      | 3        |
| <i>Warranties &amp; Test Certificates</i> | <i>4</i> |
| Case Studies                              | 5        |
| Terms & Conditions                        | 6        |



Warranties  
& Test  
Certificates



# Guarantees

Proludic

## 2, 5, 10 and 25 years

**Proludic is committed to the quality and durability of its products. In addition to using carefully selected materials and applying the highest manufacturing standards, Proludic provides extensive guarantees.**

### Our guarantees:

**2 years** for any defect or manufacturing fault of component parts.

**5 years** for any structural failure of sport or play products due to a material or manufacturing failure of:

- Springs
- Moulded or rotary moulded plastic parts (with the exception of moving or mechanical parts)
- Metal crimps and rope assemblies

**10 years** for any structural failure of sport or play products due to a material or manufacturing failure of:

- Metal components (with the exception of springs, moving or mechanical parts and fixings)
- High density plastic parts (with the exception of moving or mechanical parts)
- Non-slip plywood and compact panels
- Posts (timber)

**25 years** for any structural failure of sport or play products due to a material or manufacturing failure of:

- Panels (lacquered plywood / coloured compact / polyethylene)
- Posts (painted galvanised steel, galvanised steel, stainless steel)
- Stainless steel tubes

The colours reproduced in this brochure may not be true to life, Proludic reserves the right to change specifications and make product improvements to any of our products at any time without notice. Information in this brochure was correct at the time of printing.

While every effort has been made to ensure the accuracy of information, Proludic cannot accept any responsibility for any errors or omissions and this brochure does not form part of any contract.

*Crédits photos : Proludic & Fotosearch*



## A Practical and Proactive Approach to Safety

Every piece of Proludic play equipment has been manufactured to conform to the current European standards.

Proludic equipment has been inspected and certificated by an independent laboratory (TUV) to conform to the European standards EN 1176.

Proludic Sport abides by the European legislation in place and makes the DIN, NF, and EN standards an integral part of part of both its design and testing stages. Our design teams are involved in the development of these safety standards in order to ensure the safety of our users while offering them exciting opportunities.

The main certifications provided are issued by the German TUV safety and testing organisation.



# CERTIFICATE OF MEMBERSHIP

---



Supporting the  
**UK Play** Industry

This is to certify that

---

**Proludic Ltd**

---

Has been accepted as a member of the Association of Play Industries

*Deborah Holt*

---

Deborah Holt, Membership Manager

MEMBERSHIP P0112

VALID FOR 2021





The Health and Safety Management System of  
**Proludic Ltd**

has been assessed against the **SSiP Core Criteria** by  
**CHAS**  
and through SSiP Deem-to-Satisfy the company has  
been awarded **SMAS Worksafe** accreditation.

**Contractor**

Certificate expiry date

01/10/2021

Certificate number

104304

Signed on behalf of  
**Safety Management Advisory Services Ltd.**

A handwritten signature in black ink, appearing to read 'A. McKay', written over a horizontal line.

A registered member scheme of  
**Safety Schemes In Procurement (SSiP)**



To check the validity of this certificate please contact SMAS Ltd directly  
by phone **01752 697370** or email **info@smasltd.com**



The Health and Safety Management System of  
**Proludic Ltd**

has been assessed against the **SSiP Core Criteria** by  
**CHAS**  
and through SSiP Deem-to-Satisfy the company has  
been awarded **SMAS Worksafe** accreditation.

**Principal Contractor**

Certificate expiry date

01/10/2021

Certificate number

104304

Signed on behalf of  
**Safety Management Advisory Services Ltd.**

A handwritten signature in black ink, appearing to read 'A. McKay', written over a horizontal line.

A registered member scheme of  
**Safety Schemes In Procurement (SSiP)**



To check the validity of this certificate please contact SMAS Ltd directly  
by phone **01752 697370** or email **info@smasltd.com**

**BUREAU VERITAS**  
Certification



**PROLUDIC**

ZI L'ETANG VIGNON  
37210 VOUVRAY - FRANCE

*Bureau Veritas Certification France certifie que le système de management de l'organisme susmentionné a été audité et jugé conforme aux exigences de la norme :*

*Standard*

**ISO 9001:2015**

*Domaine d'activité*

**CONCEPTION, FABRICATION, COMMERCIALISATION ET  
INSTALLATION DE JEUX DE PLEIN AIR A USAGE COLLECTIF  
ET D'EQUIPEMENTS SPORTIFS EN ACCES LIBRE.**

**DESIGN, MANUFACTURING, MARKETING, SALE, INSTALLATION  
OF FREE-ACCESS AND OUTDOOR PLAY EQUIPMENT  
AND RELATED SPORTS EQUIPMENT.**

Date d'entrée en vigueur : **18 avril 2019**

Sous réserve du fonctionnement continu et satisfaisant du système de management de l'organisme, ce certificat est valable jusqu'au : **15 avril 2022**

Certificat n° : **FR052133-1**

Affaire n° : **7194920**

Date: **23 avril 2019**

\_\_\_\_\_  
**Jacques Matillon - Président**

Adresse de l'organisme certificateur : Bureau Veritas Certification France  
60, avenue du Général de Gaulle – Immeuble Le Guillaumet - 92046 Paris La Défense

Des informations supplémentaires concernant le périmètre de ce certificat ainsi que l'applicabilité des exigences du système de management peuvent être obtenues en consultant l'organisme.  
Pour vérifier la validité de ce certificat, vous pouvez téléphoner au : **+ 33 (0)1 41 97 00 60**.



**BUREAU  
VERITAS**

**cofrac**  
  
**CERTIFICATION  
DE SYSTEMES  
DE MANAGEMENT**  
ACCREDITATION  
N°4-0002  
Liste des sites et  
portées disponibles  
sur [www.cofrac.fr](http://www.cofrac.fr)



**BUREAU VERITAS**  
Certification



**PROLUDIC**

ZI L'ETANG VIGNON  
37210 VOUVRAY - FRANCE

*Bureau Veritas Certification France certifie que le système de management de l'organisme susmentionné a été audité et jugé conforme aux exigences de la norme :*

*Standard*

**ISO 14001:2015**

*Domaine d'activité*

**CONCEPTION, FABRICATION, COMMERCIALISATION ET  
INSTALLATION DE JEUX DE PLEIN AIR A USAGE COLLECTIF  
ET D'EQUIPEMENTS SPORTIFS EN ACCES LIBRE.**

**DESIGN, MANUFACTURING, MARKETING, SALE, INSTALLATION  
OF FREE-ACCESS AND OUTDOOR PLAY EQUIPMENT  
AND RELATED SPORTS EQUIPMENT.**

Date d'entrée en vigueur : **18 avril 2019**

Sous réserve du fonctionnement continu et satisfaisant du système de management de l'organisme, ce certificat est valable jusqu'au : **15 avril 2022**

Certificat n° : **FR052134-1**

Affaire n° : **7194920**

Date: **23 avril 2019**

\_\_\_\_\_  
**Jacques Matillon - Président**

Adresse de l'organisme certificateur : Bureau Veritas Certification France  
60, avenue du Général de Gaulle – Immeuble Le Guillaumet - 92046 Paris La Défense

Des informations supplémentaires concernant le périmètre de ce certificat ainsi que l'applicabilité des exigences du système de management peuvent être obtenues en consultant l'organisme.  
Pour vérifier la validité de ce certificat, vous pouvez téléphoner au : **+ 33 (0)1 41 97 00 60**.



**BUREAU  
VERITAS**

**cofrac**



**CERTIFICATION  
DE SYSTEMES  
DE MANAGEMENT**

ACCREDITATION  
N°4-0002  
Liste des sites et  
portées disponibles  
sur [www.cofrac.fr](http://www.cofrac.fr)



# CERTIFICATE OF ACCREDITATION

This is to certify that

## Proludic Ltd

has demonstrated compliance with the CHAS standards in line with SSIP Core Criteria and UK H&S Legislation and has been awarded accreditation to the requirements of the CDM Regulations 2015. Additionally has demonstrated full compliance with 6 modules of PAS 91.



Principal Contractor

**PREMIUM**

**PLUS**

VALID UNTIL

**01**

**020 8545 3838**

**OCTOBER**

**CHAS.co.uk**

**2021**



*Ian McKinnon*  
**Ian McKinnon**  
Managing Director



STANDARD



REGISTERED MEMBER

CERTIFICATE OF ACCREDITATION

This is to certify that

Proludic Ltd

Membership No.: CHAS-134536
Principal Contractor

has demonstrated compliance with the CHAS standards in line with SSIP Core Criteria and UK H&S Legislation and has been awarded accreditation to the requirements of the CDM Regulations 2015



[Signature]

Ian McKinnon
Managing Director

MEMBERSHIP VALID UNTIL 26 SEPTEMBER 2022

CERTIFICATE VALID UNTIL\* 12 NOVEMBER 2022

\*Certificate is only valid when accompanied with an active membership.

0345 521 9111

CHAS.co.uk

# Blade Warranty

---

The Urbanix Warranty is more than just a word, it's a personal commitment that you will be satisfied with your purchase. In our many years of selling outdoor fitness equipment, rigorous testing and field use of our products has resulted in top quality and proven high performance. We are confident knowing that you will get your money's worth.

Guaranteed customer satisfaction, thicker steel, better paint, galvanization and a better design are just some of our advantages.

## All products come with a warranty.

The warranty assumes that all products are shipped free from manufacturing defects in materials, structure, workmanship or finish. The warranty does not include damage resulting from abuse, negligence, misuse, extreme weather conditions, accidents, shipping damage, fire, flood or any other condition that would not be considered normal use or normal facility application. Any warranty disputes will be at the sole discretion of the manufacturer who reserves the option to replace, repair, or refund if the product is found defective upon inspection. A clear photograph of the defect also may be necessary to support the claim.



### 2 Years Limited Warranty

For all Urbanix gym equipment in whole, Hydraulic and moving systems, bearing, handles and cushions under normal conditions.



### 10 Years Limited Warranty

For all Urbanix Blade outdoor gym equipment main posts, steel tubes and welding procedure against structural failure due to manufacturing defects.



### 25 Years Limited Warranty

For all Urbanix Blade outdoor gym equipment aluminum and stainless hardware against structural failure and corrosion due to manufacturing defects.

*This warranty does not include any cosmetic issues or wear and tear from normal use. It is valid only if the equipment are erected to conform to installation instructions and maintained according to the maintenance procedures.*

## *Contents*

|   |   |
|---|---|
| <i>Site Plan &amp; Design</i>             | 1 |
| <i>Pricing Breakdown</i>                  | 2 |
| <i>Technical Datasheets</i>               | 3 |
| <i>Warranties &amp; Test Certificates</i> | 4 |
| <i>Case Studies</i>                       | 5 |
| <i>Terms &amp; Conditions</i>             | 6 |



*Proludic - Committed to being your perfect partner*

# Knowsley Centre of Excellence

## 15 Diverse Fitness Sites Across Knowsley

Client: Knowsley Borough Council

Address: Across 15 Sites in Knowsley (Available on Request)

Budget: £300,000

Age Range: 14+ Years

Case Study Video Here 

### Project Story

Knowsley Borough Council wanted to deliver 15 diverse fitness sites under the Green Gym Initiative. They knew through statistics that Knowsley was suffering from high inactivity levels and they wanted to address this. They strategically chose 15 sites across the borough, 14 of which were in some of the most deprived areas; that would allow all residents to benefit from free, accessible and quality leisure facilities. The council wanted each site to be bespoke and unique to the varied environments. They wanted great care and attention given to the choice of equipment, aesthetic fit and also the quality of the product.

In 2013 Knowsley adults were identified as exercising less than the national average, the average life expectancy — Men 56.9yrs and women 57.5yrs. 23% of deaths were caused by cardiovascular disease.

We partnered with Knowsley Council to produce 15 unique and impressive sites which will cater for the whole community providing 146,000 residents with free, accessible and quality fitness facilities within 10mins from their home.

After



“ Part of the reason we chose Proludic as our partner was the diverse range of equipment that they could offer. They have delivered a brilliant project that will help benefit the community for years to come. ”

- Caroline Davies, Public Open Spaces Manager



# Opening



## Spinning Bike



## Trim Trail



## Vitality Station



## Proludic Sport App

The FREE app, called 'Proludic Sport', is available to download on both Android and Apple/iOS devices. It has been devised to simply and easily allow users to monitor and track their exercise on Proludic sports equipment. Earn rewards by exercising, compete with other users and communities across the country.

- Detailed descriptions of the equipment
- Recommended workout routines
- Pre-designed workouts
- Customisable workouts
- Apple health integration
- Community and personal leader boards
- Challenge your friends
- 30+ unique exercises.



## *Contents*

|   |   |
|---|---|
| <i>Site Plan &amp; Design</i>             | 1 |
| <i>Pricing Breakdown</i>                  | 2 |
| <i>Technical Datasheets</i>               | 3 |
| <i>Warranties &amp; Test Certificates</i> | 4 |
| <i>Case Studies</i>                       | 5 |
| <i>Terms &amp; Conditions</i>             | 6 |





## Terms and Conditions

### Formation of a Contract

The quotation given on or attached to these terms and conditions will remain valid for a period of 90 days, unless otherwise stated on the quote. Acknowledgment and acceptance of this proposal is made by you placing an order within the specified period above, at which time you will be bound by these terms and conditions. Each proposal accepted shall constitute an individual legally binding contract between you and us. Such contract is hereinafter referred to in these terms and conditions as "an order". Nothing in these terms and conditions shall prejudice any condition or warranty expressed or implied, or any legal remedy to which we may be entitled in relation to the goods / and or the work the subject of this order.

### Our Responsibility

We will ensure that all materials supplied comply with safe building practices and are free from defects and that any work carried out is carried out with reasonable care and skill and to a reasonable standard. Before starting any work we will carry out an inspection to make sure that all work quoted is appropriate and practicable. If after our inspection any further work is necessary either because of alterations in design, specification or otherwise and this causes an increase in costs we will send you a further proposal giving details of the extra costs and will only proceed with the works once your written acceptance has been received. Subject to our terms we will carry out the work in accordance with our proposal. We will make good any damage caused whilst carrying out the work.

### Your Responsibility

You will permit us during normal working hours to carry out an inspection and thereafter to undertake the works according to the programme set out in the proposal. You will remove all items necessary to allow us to commence the works and cover and protect all fixtures and fittings, which cannot be removed. You will obtain all permissions and consents, (including if necessary planning permission) from landlords, local authorities and others, which are required before the work can commence. Where you are required to provide us with measurements or other information such measurements or information must be correct. If we rely on the measurements or information given when preparing our proposal and such measurements or information are incorrect we reserve the right to increase the price to make good any errors or additional works required as a result.

### Payment

Goods are invoiced upon dispatch. Payment terms are strictly net 30 days from the date of invoice. Acceptance of this order constitutes agreement of these terms and overrides any other payment terms, including any quoted on your purchase order. We reserve the right to issue interim invoices or applications for payment, or request payment prior delivery or installation on a proforma basis. Please note all prices quoted are excluding VAT.

### Delivery/Installation Dates

UK delivery is priced at 9% (with a minimum £100 charge) based on the total list price value of the equipment. We reserve the right to increase the delivery charge dependent on location of delivery address, all amended prices will be notified on quotations. You will be provided with an estimated delivery date on receipt of order and updated throughout the order process. Delivery is approximately 4-6 weeks from the date of order. Deliveries that cannot be accepted by the customer within 4 weeks of the agreed date, will be subject to a storage charge of £100 per week or 1% of the equipment value, whichever is greater

### Minimum Installation Charge

On orders received with installation, a minimum installation charge per site of £1000 applies in all cases.

Budget costs assume that easy lorry access & precise siting of the equipment will be provided, no surface or underground obstructions will be encountered during excavation such as concrete, hard-core, rock, chalk, roots, drainage, gas or water pipes, telephone or electricity cables etc. In the event of any such obstructions we reserve the right to charge for any additional work involved. We cannot accept liability for any consequent charges that may be incurred by disruption of any of the foregoing services. For fixed installation prices, a site survey is required by a company representative prior to the order being placed

### Main Contractor's Discount

Our quotation does not include for a Main Contractor's Discount. If a 2.5% Main Contractor's Discount is applicable, please add 2.563% to our quoted prices.

### Cancellation Policy

The Company reserves the right to levy a cancellation charge of:

- 25% of the total order value if cancelled more than 6 weeks from the scheduled delivery / start date.
- 50% of the total order value if cancelled less than 6 weeks from the scheduled delivery / start date.

Please Note: Any such charge is non-negotiable and is solely at the discretion of the Company. All drawings, descriptive and forwarding specifications, particulars of weights and dimensions are approximate only and not binding and illustrations contained in catalogues, price lists, sales literature and other advertisement material are for the purpose of general description only and none of these shall form part of this Contract.

The Play Hub, Bradmore Business Park, Loughborough Road, Nottingham NG11 6QA



Designer of play and sports areas

Proludic Ltd  
The Play Hub,  
Bradmore Business Park,  
Loughborough Road  
Nottingham,  
NG11 6QA  
Tel: 0115 982 3980  
info@proludic.co.uk



Area Manager - Kiran Chouhan

[WWW.PROLUDIC.CO.UK](http://WWW.PROLUDIC.CO.UK)





## Sales - Quote



Ms. Hilary Workman  
Wickhambrook Parish Council  
6 Coltsfoot Close  
Wickhambrook, NEWMARKET  
CB8 8UP

Quote No. SQ265984-1  
Sell-to Contact No. 630032  
Quote Date 09-11-2021  
Expiration Date 09-12-2021

Salesperson Helen Sephton-Pike  
E-Mail helsep@kompan.com  
Phone No. 07764 365669

Project Name EN28765 Outdoor Fitness Equipment

| No.                           | Description  | Quantity | Unit of Measure | Unit Price | Amount   |
|-------------------------------|--|----------|-----------------|------------|----------|
| <a href="#">FAZ10100-0901</a> | KOMPAN Suspension Trainer, colour grey<br>Inground<br>        | 1        | Pieces          | 9,430.00   | 9,430.00 |
| INSTALLATION                  | Installation - FAZ10100-0901<br>KOMPAN Suspension Trainer, colour grey   | 1        | Pieces          | 1,044.00   | 1,044.00 |
| <a href="#">FSW20300-0900</a> | KOMPAN Bench<br>Inground, colour grey<br>                   | 1        | Pieces          | 1,130.00   | 1,130.00 |
| INSTALLATION                  | Installation - FSW20300-0900<br>KOMPAN Bench   | 1        | Pieces          | 213.00     | 213.00   |
| <a href="#">FSW22700-0900</a> | KOMPAN Balance Station, colour grey RAL7016<br>Inground<br> | 1        | Pieces          | 5,800.00   | 5,800.00 |
| INSTALLATION                  | Installation - FSW22700-0900<br>KOMPAN Balance Station, colour grey RAL7016  | 1        | Pieces          | 800.00     | 800.00   |
| <a href="#">FSW23100-0900</a> | KOMPAN Balance Board, colour grey RAL7016<br>Inground<br>   | 1        | Pieces          | 2,190.00   | 2,190.00 |
| INSTALLATION                  | Installation - FSW23100-0900<br>KOMPAN Balance Board, colour grey RAL7016  | 1        | Pieces          | 617.00     | 617.00   |

| No.                           | Description   | Quantity | Unit of Measure | Unit Price | Amount   |
|-------------------------------|---|----------|-----------------|------------|----------|
| <a href="#">FAZ51100-0800</a> | KOMPAN Arm Bike<br>Inground, colour grey  | 1        | Pieces          | 4,990.00   | 4,990.00 |
|                               |    |          |                 |            |          |
| INSTALLATION                  | Installation - FAZ51100-0800<br>KOMPAN Arm Bike                                     | 1        | Pieces          | 478.00     | 478.00   |
| <a href="#">FAZ52100-0800</a> | KOMPAN Cross Trainer, colour grey RAL7016<br>Inground                               | 1        | Pieces          | 8,160.00   | 8,160.00 |
|                               |    |          |                 |            |          |
| INSTALLATION                  | Installation - FAZ52100-0800<br>KOMPAN Cross Trainer, colour grey RAL7016           | 1        | Pieces          | 955.00     | 955.00   |
| <a href="#">FAZ50200-0800</a> | KOMPAN Sport Bike<br>Inground, colour grey  | 1        | Pieces          | 5,320.00   | 5,320.00 |
|                               |   |          |                 |            |          |
| INSTALLATION                  | Installation - FAZ50200-0800<br>KOMPAN Sport Bike                                   | 1        | Pieces          | 634.00     | 634.00   |
| <a href="#">FSW10401-0900</a> | KOMPAN Combi 4, colour grey RAL7016<br>Inground                                     | 1        | Pieces          | 5,080.00   | 5,080.00 |
|                               |  |          |                 |            |          |
| INSTALLATION                  | Installation - FSW10401-0900<br>KOMPAN Combi 4, colour grey RAL7016                 | 1        | Pieces          | 1,644.00   | 1,644.00 |

| No.     | Description | Quantity | Unit of Measure | Unit Price | Amount   |
|---------|-------------|----------|-----------------|------------|----------|
| FREIGHT | Freight     | 1        | Pieces          | 2,736.50   | 2,736.50 |

This quotation is provided for budget purposes only and an order cannot be placed against it. Prices are subject to change and we endeavour to provide accurate pricing given the information available at the time of quotation.

If you require a fixed proposal then we would be pleased to provide this (subject to site survey) with a 30 day price validity.

Prices are given based on the assumption of good ground conditions and site access. All prices are subject to a full and complete site survey and CAD design.

Storage Container, site welfare, skip and heras fencing, to be provided by the client, however, KOMPAN can provide a quotation upon request.

|                            |                  |
|----------------------------|------------------|
| <b>Total GBP Excl. VAT</b> | <b>51,221.50</b> |
| 20% VAT                    | 10,244.30        |
| <b>Total GBP Incl. VAT</b> | <b>61,465.80</b> |

**Payment Terms** Net 30 days

\*Please Note our Payment Terms\*

Please see below the standard payment terms offered by KOMPAN for orders over the value of £5,000. If your project has specific payment criteria, please discuss this with us at the time you place your order.

Public Body & Local Authority Customers - (City/County/District/Borough/Town & Parish Councils)

Invoice 1: 100% of the value of your KOMPAN equipment. Issued on the day of shipment from our factory (Payable within 30 days from date of invoice).

Invoice 2: Remaining value of your project. Issued on completion (Payable within 30 days from date of invoice).

Limited, Private & Public Companies, Sole Traders, Schools & Private Individuals - (PLC, LTD, LLP, Community Interest Co.)

Invoice 1: 100% of the value of your KOMPAN equipment. Issued at point of order. (Payable within 5 days, and PRIOR to manufacture.)

Invoice 2: Remaining value of your project. Issued on completion. (Payable within 30 days from date of invoice).

Please refer to Clause 3 in our Terms & Conditions

Customer responsible for offloading; however KOMPAN can provide a quotation for a Hiab delivery upon request.

Thank you for giving KOMPAN the opportunity to provide you with a quotation. The quote is valid for 30 days and if you have any questions, please do not hesitate to contact us.

**GENERAL TERMS AND CONDITIONS OF SALE (GT&C's)**  
Release date 02/08/2021

**1. OBJECTS**

1. These terms and conditions of sale (hereinafter "GT&C's") govern the sale and supply of all goods and/or services (goods and services herein severally and jointly as "Products") and the assembly and installation of the Products ("Services") by KOMPAN LTD (hereinafter "Seller") to the customer ("Customer") and shall apply to any relationship between the Seller and the Customer.

2. These GT&C's replace and supersede any prior communications, agreements and understandings between the parties whether oral or in writing concerning the sale and supply of the Products or the Services. Any purchase order issued by the Customer to the Seller shall be subject to the present GT&C's and the Customer accepts the applicability of these GT&C's to future supplies of Products or Services.

3. A legally binding contract ("Contract") shall not come into force between the Seller and the Customer until the period of FIVE (5) BUSINESS DAYS provided for in clause 2.3 has expired and the Seller has not received a notice of withdrawal/rejection from the Customer. If, within FIVE (5) BUSINESS DAYS as of the date of the Order Confirmation the Seller does not receive a rejection of the Order Confirmation, the Customer shall be deemed to have unconditionally accepted the Order Confirmation and these GT&C's. In case of conflict between the provisions contained in the Order Confirmation and those from the present GT&C's, the Order Confirmation shall prevail.

**2. REQUEST FOR SERVICES**

1. Notwithstanding any express indication to the contrary, the Customer is obliged to send the Seller a request for the Services and/or Products (hereinafter, "Order") by ordinary post, fax and/or email.

2. For the purpose of these GT&C's, the Order must, at least, contain the following information:

- (i) personal information and address of the Customer;
- (ii) products requested (type and number);
- (iii) installation services requested;
- (iv) indication of the date and place for the provision of the Services.

3. Once the Order has been received, the Seller shall have seven (7) working days – starting from the date of receipt of the same – to issue an Order Confirmation accepting, refusing and/or submitting amendments to the Order, and including the relevant Prices – as defined hereinafter – for the Services and/or Products and the total amount to be paid by the Customer ("Order Confirmation"). The Customer will have the right to withdraw any Order within FIVE (5) BUSINESS DAYS after receiving the Order Confirmation, e.g. he does not accept the Price indicated by the Seller.

**3. RATES - PAYMENTS**

1. The prices of the Services and/or Products are those resulting from the Order Confirmation and will correspond to the current prices offered by the Seller ("Prices").

2. The Order Confirmation will indicate, apart from the Prices, other charges as transport costs, shipping and minimum insurance coverage, to the destination agreed in the same Order Confirmation. Unless expressly stated otherwise in writing, Prices in the Order Confirmation are net of all charges relating to taxes, any increases in these charges, which may come into force after the date of the Order Confirmation shall be borne by the Customer.

3. Unless expressly stated otherwise in writing, invoices will be issued:

(i) For the supply of product only orders, 100% of the Price upon dispatch.

(ii) For supply of product and services orders, 100% of the product Price upon dispatch and the remaining balance upon completion (hand over) of services.

The payment of the total value of each invoice shall be made within thirty (30) days starting from the date of the invoice unless expressly agreed otherwise.

The Seller is entitled to ask for 100% of the product Price when the Order is accepted (by credit card, money transfer or similar) and the payment of the rest upon completion (hand over) of services. In the exceptional case that the Customer does not meet financial criteria set by the Seller, the order will not be released to manufacturing until the pre-payment has been received, so the pre-payment invoice shall be made within five (5) days starting from the date of the invoice in order to achieve timely delivery.

4. For Services to be carried out over a period exceeding two weeks, the Seller reserves the right to invoice the Customer on a weekly basis. An initial invoice will be issued upon receipt of the Products at the Customer's site, followed at weekly intervals by invoices for completed stages of the Services. In the event that any weekly invoice is not paid in accordance with clause 3.3, the Seller shall be entitled at its discretion to suspend the Services until payment of all outstanding sums is received or to terminate the Contract in accordance with clause 12.1(i).

5. In the event of the non-payment by the Customer in accordance with this clause 4 the Customer shall pay the Seller interest at the legal interest rate with effect from the time of due payment, and a penalty equal to 10% of the total bill as compensation for damages, without prejudice to any further damages and any other rights arising from the non-payment.

**4. RISK AND RETENTION OF TITLE**

Unless otherwise and specifically agreed in writing, all risks relating to the Products are transferred to the Customer when the same are delivered to the carrier or freight forwarder. Notwithstanding delivery and the passing of risk in the Products, or any other provision of these GT&C's, the property in the Products shall not pass to the Customer until the Seller has received in cash or cleared funds payment in full of the price of the Products.

**5. DELIVERY**

1. Unless otherwise expressly agreed, times for delivery are estimates only and not binding and any delay in delivery does not entitle the Customer to cancel the Contract or any order nor to damages and/or compensation. Customer may only vary any delivery time set out in the Order Confirmation by giving not less than 30 days' notice in writing.

2. Unless expressly stated otherwise in the Order Confirmation, the Seller shall organize the delivery of Products CIP (as defined by Incoterms 2010) to their destination. If the carrier is unable to discharge the Products carried, the transport will still be charged. Any damage to Products caused during or after unloading by the staff of the Customer will be the exclusive responsibility of Customer.

3. The carrier shall deliver at a point readily accessible by truck, standard delivery via 18 tonne vehicle, tail lift delivery is available and to be advised at point of ordering. The Seller reserves the right to charge extra for any special delivery requirements. Customer shall be responsible for providing offloading facilities, final moving, location and storage of the Products after delivery. The Customer shall ensure that unloading by the carrier is not delayed. In the event of unloading being delayed, the Seller reserves the right to make a fair charge, therefore. Any damages or missing Products to be noted on the delivery paperwork at time of delivery.

(i) If the Customer is not available or prepared to accept delivery the Seller may take away the Products and redeliver at a later date, charging the Customer for any additional expense thereby incurred (including temporary storage and demurrage) or leave the Products on any part of the premises which is accessible without responsibility for loss or damage to them whether as a result of their being unsecured or otherwise;

**6. INSTALLATION AND ASSEMBLY SERVICE**

1. In relation to the individual needs expressly indicated by the Customer in the Services Order, the Seller shall install and assemble the Products, the paving, the civil works and any spare parts. In particular, the Customer shall promptly notify the Seller of any existing installations such as water, gas, communications, electricity, or of any other similar communications or installations which may be affected and/or may suffer damages as a consequence of the installation works to be carried out in the place where the Products are to be installed. Should the Customer fail to provide such information prior to the commencement of the Services, the Seller shall not be held liable under any circumstance for any potential or actual damages caused to such installations.

2. The Seller shall be responsible for ensuring:

- (i) the correct execution of the necessary work for the installation of the Products;
- (ii) the correct assembly of the Products; and
- (iii) compliance of the Services with the laws in force.

**7. COMPLETION OF THE SERVICES**

1. Upon completion of the Services, the Customer shall sign the Practical Completion Certificate provided by the Seller and if the Customer is not available to take delivery then the Seller will send the Practical Completion certificate to the Customer. Should the Customer claim that the Services have not been performed in accordance with the Order Confirmation, the same shall send the Seller, within five (5) working days from receipt of the Practical Completion Certificate, a notice ("Notice"), specifying in detail, the faults found in the Services. If the Customer objectively demonstrates the claimed faults, the Seller shall remedy the same at its own expense; if, instead, the Seller demonstrates that the Services are in compliance with the Order Confirmation, the Customer shall be obliged to pay the Seller the costs and expenses of the activities carried out to demonstrate the compliance of the Services. If the Customer does return a signed Practical Completion Certificate or provide a Notice within five (5) working days from receipt of the Practical Completion Certificate, the Services will be deemed completed to the Customer's satisfaction in all respects.

**8. LIABILITY**

1. In no event shall Seller be liable to Customer or any other person for any special, incidental, indirect, consequential or punitive damages obligation, nor for any loss, costs or expenses, including, without limitation, damages consisting of loss start-up, sales or profits, work stoppage, loss of production, impairment of other assets or otherwise, even if arising out of or in connection with a breach of warranty, breach of contract, false or erroneous statement, or other fault. Notwithstanding any statement to the contrary contained in these GT&C's, the Seller's liability for any claim for damages arising out of or in connection with the Products and their use or the Services shall in no case exceed the amount paid by Customer for the Products or Services which are the subject of claim.

2. The Customer hereby indemnifies and shall keep indemnified the Seller against all loss, liability, damages, costs, claims and expenses arising out of any of the matters set out in clause 8.2.

3. Notwithstanding the case in which the Seller and the Customer sign an agreement for the installation of the Products, the Customer undertakes to indemnify and hold harmless the Seller from any third party right and/or claim relating to the fault and/or non conformity of the Products being installed in the playground and/or any other location.

**9. CLAIMS – SUBSTITUTIONS – RETURNS**

1. Any complaints about defects or non-conformity of the Products must be communicated by registered mail to the Seller within 8 (eight) days after delivery of the same. After that period, the Customer will lose any right to make a claim.

2. Return of any Products must be authorized in writing by the Seller prior to shipping and all costs and expenses will be borne by the Customer.

3. The communication of defects and anomalies must be accompanied by supporting documentation. The Seller shall not be liable for defective Products, when the value of the defect reported by the Customer does not exceed 5% of the value of the Products in respect of any Order Confirmation. In any event the Customer shall take all reasonable action to mitigate any damage suffered and shall not be entitled to withhold or delay payment.

4. If the Seller acknowledges any Products to be defective the Seller is only required, at its discretion, to replace the Products or to refund the price or to reduce the price, if the Customer has not yet paid in the price, or to terminate the contract.

5. The guarantee referred to in clause 10 shall not in any way apply to damage arising out of fair wear and tear or, from failures caused by incompetence or negligence of the Customer, misuse or by Force Majeure.

6. In the scope of supply of the Products, if necessary, the Seller reserves the right to provide models other than those requested by the Customer, if these are not available, subject to compliance of the alternative models with the properties listed in the Order Confirmation.

**10. GUARANTEES**

1. The Seller warrants the Products will be free from defects in design, material and workmanship in accordance with the terms set out in the general warranty attached to the Order Confirmation after Delivery:

- 2. The terms implied by sections 13 to 15 of the Sale of Goods Act 1979 are, to the fullest extent permitted by law, excluded from the contract.
- 3. The provisions of clauses 10.1 and 10.2 shall not apply to components which are not manufactured by the Seller, in respect of which, the Seller shall, to the extent it is able, pass on any warranty given to it by the manufacturer of the component in question.

4. The Customer shall indemnify and hold harmless the Seller against all damages, losses, costs, expenses, claims, demands and liabilities arising out of or related to the Products and their use by the Customer and/or use or application by the same of any information disclosed or provided by or on behalf of Seller.

**11. TERMINATION**

1. A party shall be entitled to terminate this agreement with immediate effect by giving written notice to the other party if:

- (i) the other party fails to pay any undisputed amount due under this agreement on the due date for payment and remains in default not less than 14 days after being notified in writing to make such payment; or
- (ii) the other party commits a material breach of its obligations under this agreement and (if such breach is remediable) fails to remedy that breach within a period of 30 days after receipt of notice in writing requiring it to do so; or
- (iii) the other party becomes insolvent, or an order is made or a resolution is passed for the winding up of the other party (other than voluntarily for the purpose of solvent amalgamation or reconstruction), or an administrator or administrative receiver is appointed in respect of the whole or any part of the other party's assets or business, or the other party makes any composition with its creditors, or the other party takes or suffers any similar or analogous action in consequence of debt.

2. Termination of this agreement shall not prejudice any of the parties' rights and remedies which have accrued as at termination and all payments which have not yet become due shall become immediately due and payable.

**12. INTELLECTUAL AND INDUSTRIAL PROPERTY**

1. Any authorization by one of the parties to use the brands, names, logos and/or any other distinctive signs of the other party does not imply any right whatsoever to transfer the property of the same to the party utilizing them.

**13. ADMINISTRATIVE PERMISSIONS**

The Customer is solely and exclusively responsible for obtaining and maintaining the building authorizations and any other authorizations required for carrying out the supply of the Products or Services and their utilization. Where the Seller is providing Services if agreed, a copy of said authorizations and related and essential attachments, must be forwarded to the Seller before commencement of the Services.

**14. FORCE MAJEURE**

1. A party shall not be deemed to be in breach of the Contract, or otherwise be liable to the other, by reason of any delay in performance, or non-performance, of any of its obligations hereunder (save for obligations relating to payment of any sums due) to the extent that such delay or non-performance is due to Force Majeure and the time for performance of that obligation shall be extended accordingly.

2. For the purposes of these GT&C's Force Majeure means any cause materially affecting the performance by a party of its obligations under this agreement arising from any act, events, omissions, happenings or non-happenings beyond its reasonable control including, without limitation, acts of God, strikes, lock-outs or other industrial disputes, war, riot, fire, flood, or any disaster affecting either one of the parties hereto or a third party for which a substitute third party is not reasonably available.

**15. DATA PROTECTION**

1. Seller and Customer each act as independent data controllers in relation to the personal data collected and processed in connection with any sale and execution of the parties' obligations under these GT&C's.

2. Each party must in connection with execution of their obligations under these GT&C's act in compliance with applicable data protection legislations and regulations.

3. Information regarding Seller's processing of personal data can be found in KOMPAN's privacy policy on [www.kompan.com](http://www.kompan.com).

**16. GENERAL**

1. Any notice or other communication required to be given to a party under or in connection with this Contract shall be in writing and shall be delivered to the other party personally or sent by prepaid first-class post, recorded delivery or by commercial courier, at its registered office (if a company) or (in any other case) its principal place of business, or sent by fax to the other party's main fax number. Any notice or other communication shall be deemed to have been duly received if delivered personally, when left at such addresser, if sent by prepaid first-class post or recorded delivery, at 9.00 am on the second Business Day (for the purposes of this clause 15 being any day other than Saturday, Sunday or ant public holiday in England and Wales) after posting, or if delivered by commercial courier, on the date and at the time that the courier's delivery receipt is signed, or if sent by fax, on the next Business Day after transmission.

2. If a court or any other competent authority finds that any provision of the Contract (or part of any provision) is invalid, illegal or unenforceable, that provision or part-provision shall, to the extent required, be deemed deleted, and the validity and enforceability of the other provisions of the Contract shall not be affected.

3. A person who is not a party to the Contract shall not have any rights under or in connection with it.

4. Except as set out in these Conditions, any variation, including the introduction of any additional terms and conditions, to the Contract shall only be binding when agreed in writing and signed by the Supplier.

5. A waiver of any right under the Contract is only effective if it is in writing and shall not be deemed to be a waiver of any subsequent breach or default. No failure or delay by a party in exercising any right or remedy under the Contract or by law shall constitute a waiver of that or any other right or remedy, nor preclude or restrict its further exercise. No single or partial exercise of such right or remedy shall preclude or restrict the further exercise of that or any other right or remedy. A person who is not party to the Contract shall not have any rights under or in connection with it.

6. The Contract, and all disputes or claims arising out of or in connection with it or their subject matter or formation (including non-contractual disputes or claims), shall be governed by and construed in accordance with the law of England and Wales.

7. The parties irrevocably agree that the courts of England and Wales shall have exclusive jurisdiction to determine any dispute or claim that arises out of or in connection with the Contract or its subject matter or formation (including non-contractual disputes or claims)

## WARRANTIES & GUARANTEES

### Equipment

We have enhanced our warranties over and above what is stated in the product data sheets to the following:



#### LIFETIME\* warranty

- Hot-dip galvanised structural parts
  - Steel poles
  - Cross beams
  - Floor frames
  - Top brackets
- Stainless steel hardware
- EcoCore and other high-density polyethylene (HDPE) panels



#### 15 years warranty

- Robinia wood parts
- High pressure laminate (HPL) parts
- Aluminium parts



#### 10 years warranty

- Painted top layer of galvanised or aluminium metal posts & parts
- Pre-galvanised metal parts with painted top layer
- Solid plastic parts
- Transparent PC panels e.g., Giants
- Wood-plastic composite (WPC)
- Siberian larch, pine and other wood types
- Stainless steel slides
- Hollow plastic parts
- Rope & net constructions
- Corocord "S" clamps



#### 5 years warranty

- Resin-coated plywood parts
- Springs and ball bearing assemblies
- Graphic print on transparent PC panels e.g. Giants
- Concrete elements
- Galaxy connection balls



#### 2 years warranty

- Movable plastic & metal parts
- Rubber membranes
- Screens and electronic parts
- Sunshades and sail solutions

\* KOMPAN's LIFETIME warranty is in effect for the lifetime of the product until the product is uninstalled and/or taken out of use.

### 1. Warranty coverage

This warranty applies to KOMPAN's products and spare parts for the time periods described for each product type above and with the limitations described in this warranty. The warranty period applies from the date of purchase by the first customer. This warranty covers only defects in materials. KOMPAN's liability under this warranty is limited to repair or replacement of defective products, without charge, at KOMPAN's discretion. Defective electronic components will be delivered and changed by a KOMPAN ICON Professional installer free of charge.

### 2. Proper installation and maintenance

The warranty only applies if KOMPAN's products have been installed according to the instructions provided by KOMPAN and maintained correctly according to the KOMPAN Maintenance Manual. The warranty for the ICON electrical components is dependent on those products being installed by an ICON trained and approved installer.

### 3. Warranty exclusions

This warranty does not cover any damage caused by accident, improper care, negligence, normal wear and tear, surface corrosion on metal parts, discoloured surfaces and other cosmetic issues or failures due to misuse or vandalism. Natural changes in wood over time are considered cosmetic issues and are not covered.

### 4. Near water installation

Products installed in direct contact with chlorinated water or saltwater (Waterparks), or products installed within 200 metres from the shore are not covered by the KOMPAN warranty for any defects caused by corrosion.

Special designed products (handled via department for customised products and upgraded to corrosion class C4) installed within 200 metres from the shore will be covered by a 5-year warranty against defects caused by corrosion.

### 5. Third party supplied products & services.

KOMPAN provides non-KOMPAN branded products and installation services performed by certified third party suppliers. This general KOMPAN warranty does not apply to such non-KOMPAN branded products and installation services, which may carry their own warranties. KOMPAN will pass on information on such warranties where possible.

*In addition, KOMPAN's general terms & delivery conditions apply and supplement this warranty.*

## Installation

Following a review of the scope of works, client specification requirements and location we will identify our preferred sub-contractors for the project. We ensure that our sub-contractor can support the social value objectives of the client, such as local employment or local purchasing of materials, and is also from our approved installed list.

All KOMPAN installations have a **12-month defect liability** period from the date of handover. Any snagging issues that have been identified and agreed at completion will be addressed by your Contract Manager within 10 working days, by bringing our sub-contractors back to site to until all parties are satisfied with the quality of the workmanship that is required to meet the specification.





## SUSTAINABILITY

When the world's leading playground provider goes the extra mile for the environment, it matters! That's why we constantly continue to optimise our materials and production processes to take sustainability to even higher levels.

All KOMPAN factories comply with ISO 14001 which is the principal management system standard that specifies the requirements for the formulation and maintenance of an Environmental Management System that helps to control our environmental aspects reduce impacts and ensure legal compliance.

✦ KOMPAN has several green certificates:

- ISO9001 Quality Management
- ISO14001 Environmental Management

✦ OHSAS18001 Health and Safety Management

✦ Member of the "Green Company"

✦ A new green concept – EcoCore™ material

- Core produced from 100% recycled material
- Recyclable after use
- Supported by our lifetime warranty



✦ We request the same environmental policy from our suppliers of raw materials & services

**KOMPAN uses recycled materials in more than 70% of our products and 95% can be recycled at the end of their lifecycle.**

At KOMPAN, sustainability isn't just an added benefit; it's built into all products, right from the very beginning. We design our playgrounds to last a lifetime, ensuring minimal environmental impact and providing maximum value to the community.

### Panels HDPE: Eco-Core

100% recyclable after use

### Moulded Items

(Roto moulded/Blow moulded/Injection moulded)  
100% recyclable after use (PA, PP, PC, PE, TPE)

### Aluminium (Lead Free)

100% recyclable after use

### Cardboard Packaging

80% recycled content  
100% recyclable after use

### Stainless Steel, Galvanised and Powder Coated

Recycled steel in min. 50% (industrial standard – post consumer)  
100% recyclable after use

# Maintenance Manual

KOMPAN outdoor products

# Congratulations on choosing a KOMPAN play structure!

You have chosen a high-quality product that will withstand many years of use with proper maintenance. KOMPAN carefully designs and manufactures its play structures with safety features in compliance with all current standards.

In order to protect children's safety, KOMPAN recommends all play structures and the surrounding resilient surfaces to be inspected and maintained to ensure the play area remains safe and trouble-free.

**Responsibility of maintaining the structure and its surroundings to ensure the play structure remains safe belongs to the owner.**

Please visit the KOMPAN website <https://www.kompan.co.uk/warranty-global-menu> to see our general product warranty and if you have any questions or need assistance, please feel free to contact your Sales Representative or back office:

**KOMPAN Ltd**

21 Roebuck Way  
Knowhill  
Milton Keynes  
Buckinghamshire  
MK5 8HL

Phone: 01908 202002  
Fax: 01908 201007  
E-mail: [kompan.uk@kompan.com](mailto:kompan.uk@kompan.com)  
Website: [www.kompan.com](http://www.kompan.com)



# Warning

**Failure to follow these inspection and maintenance instructions could result in unsafe conditions on and around the play structure and possibly lead to serious physical injury during use. KOMPAN A/S are not responsible for any injuries or damages that are the result of a failure to follow these instructions.**

**Following our maintenance instructions are also necessary for the products to be covered by the KOMPAN General warranty.**

Inspections and maintenance of play structures should be scheduled on a regular basis. If your play structure is used heavily, or is located where the climate is severe, it may require more frequent attention than the recommendation of this manual.

On the following pages of this document you'll find our general maintenance instruction specifying how to inspect and if necessary, maintain your product.

Occasionally, parts may need to be replaced due to breakage or wear. Parts should be replaced immediately to avoid dangerous conditions and repairs should be completed in accordance with this maintenance manual and the installation instructions.

Information about replacement parts and copies of installation instructions can be obtained through our KOMPAN Master website (see next page) or KOMPAN's Aftersales Customer Service Team. Kerry Bowers is our Senior Aftersales Coordinator who along with the team can support you with identification of spare parts, warranty queries and quotations for our maintenance and repair services.

Opening hours: Monday – Friday 8:30am – 5pm  
Phone: 01908 207429  
E-mail: [sparepartsuk@kompan.com](mailto:sparepartsuk@kompan.com)

If any repairs cannot be performed immediately, action must be taken to restrict access to that portion of the play structure or the whole structure if necessary.

## Disposal and Recycling:

All KOMPAN products are as far as possible designed to be disassembled and recycled after a long life on the playground.

Recycling must be done according to local procedures and recommendations:

- ✦ Metal components can be recycled directly.
- ✦ Plastic components are in general marked with type of material and can be recycled accordingly.
- ✦ Wood must be disposed according to local regulations.
- ✦ Electrical parts must be disposed for recycling.

# KOMPAN Master

On KOMPAN Master you can find a lot of relevant information. Most important is the installation instructions. These were provided with the product, but we know they often disappear or are damaged during installation. Installation instructions are also the key to identifying spare parts.

Below are the steps to access the instructions:

1. Open the webpage: <http://www.kompanmaster.com/KompanMaster/login>.
2. If you have not logged in before, please click on "Apply here" to obtain a Username and Password. The Username and Password will be emailed to you.
3. Using your assigned Username and Password, log in.
4. Scroll towards the bottom of your screen and in the product number box, enter the number of your product, and click on "Product search"
5. Once the correct product is found, enter the purchase date and foundation type for your product and click the arrow, and then click on the "Find Spare Parts" button.
6. Now you can open the instructions directly or download a full package of every instruction you would have received with the product.

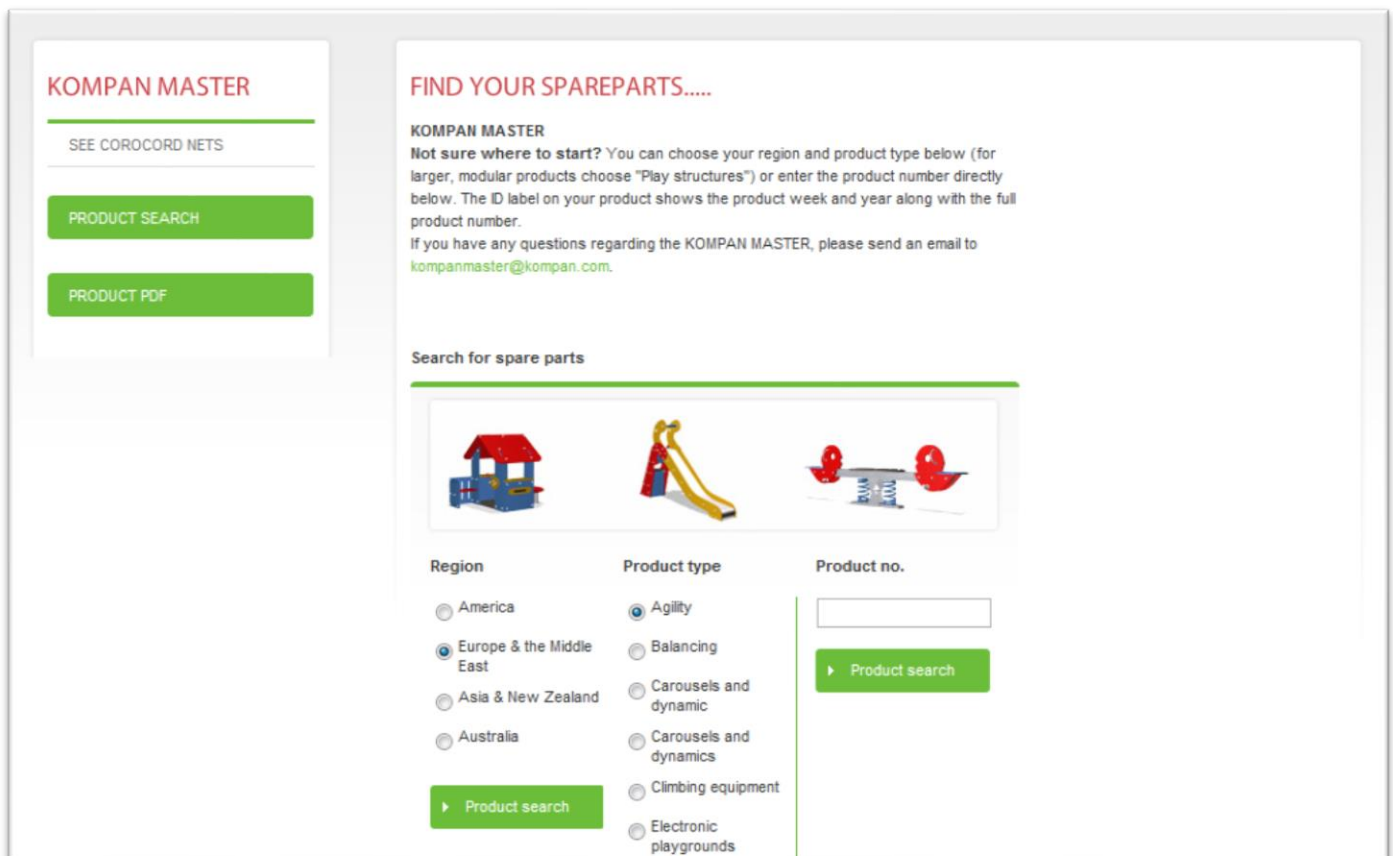

**KOMPAN MASTER**

SEE COROCORD NETS



PRODUCT SEARCH

PRODUCT PDF

**FIND YOUR SPAREPARTS.....**

**KOMPAN MASTER**  
**Not sure where to start?** You can choose your region and product type below (for larger, modular products choose "Play structures") or enter the product number directly below. The ID label on your product shows the product week and year along with the full product number.  
 If you have any questions regarding the KOMPAN MASTER, please send an email to [kompanmaster@kompan.com](mailto:kompanmaster@kompan.com).

Search for spare parts

|   |   |   |
|---|---|---|
| <b>Region</b><br><input type="radio"/> America<br><input checked="" type="radio"/> Europe & the Middle East<br><input type="radio"/> Asia & New Zealand<br><input type="radio"/> Australia<br><input type="button" value="Product search"/> | <b>Product type</b><br><input checked="" type="radio"/> Agility<br><input type="radio"/> Balancing<br><input type="radio"/> Carousels and dynamic<br><input type="radio"/> Carousels and dynamics<br><input type="radio"/> Climbing equipment<br><input type="radio"/> Electronic playgrounds | <b>Product no.</b><br><input type="text"/><br><input type="button" value="Product search"/> |
|---|---|---|

# Identification of product

All KOMPAN products come with two identification Do-Nut labels to be placed inside two Do-Nut caps according to specification.

The following information appears from the ID-labels:

## No. 1 – Product ID

Production week and year  
Product ID

## No. 2 – Supplier ID

KOMPAN address (subsidiary or importer) in  
the country concerned.

**It is of vital importance that the information from the ID-labels is given when making a complaint or ordering spare parts.**

In case the ID label is not in place and you do not have the ID information from your invoice or other documents provided with the product - we recommend you take a couple of photos and ask your local KOMPAN office for assistance.

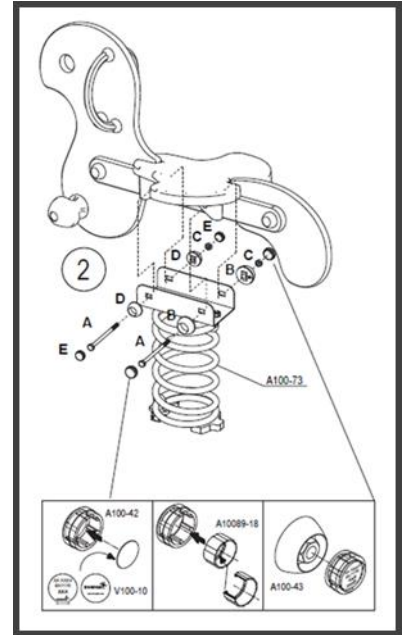

# Inspections

Daily/weekly inspections can be performed visually to identify developing problems. Monthly/seasonal inspections should be recorded in a maintenance log. Annually a comprehensive report should be written and entered into a file with all other documentation regarding the play structure.

We recommend the owner/operator establishes a file for the play structure or entire playground. This file should contain at least the following.

- ✘ Maintenance instructions.
- ✘ Installation instructions.
- ✘ Sales and warranty documentation.
- ✘ Maintenance logs.
- ✘ Comprehensive annual inspection reports.

Templates for maintenance inspections can be downloaded from [www.kompanmaster.com](http://www.kompanmaster.com)

# Spare Parts

It is important for warranty and safety conditions to use only original KOMPAN spare parts. Part numbers can be identified on the installation instructions – which can be found on KOMPAN Master (see page 3).

# Robinia

## Robinia, like any other species of wood, is a natural and organic material

Robinia will potentially have numerous knots, cracks on the surface and other patinas. The appearance of Robinia wood changes according to the weather conditions and humidity. These are not necessarily imperfections; they are completely natural and give our playground equipment the benefit of an ecological and adventurous design.

## The tension in Robinia causes openings in the ends as well as along the sides of the posts

These do not affect the strength of the structure and do not carry any additional risk of rot or fungus. This is just a natural reaction that might happen with Robinia and is normally not a safety or a quality issue.



During routine inspections and maintenance, severe deformation must be addressed if it appears on vital areas of the play structure. For example, if an opening appears near a play element that has forced movement (slides, fireman's pole, etc.) issue of openings and checking is addressed in accordance with current safety standards in the specific market. If a deformation in the wood does not conflict with the current safety standards, it is considered a beneficial characteristic provided by the organic wood Robinia!

# Fastener Maintenance

Over time, some bolts may become loose through heavy use. Loose components on play structures can cause dangerous pinch, crush, or shear points as well as excessive wear. It is therefore important that all nuts, bolts, and screws be checked periodically.

## Do-Nut/Bolt Inspection and Maintenance

Do-Nuts are used on various KOMPAN products to cover bolt heads and potentially sharp bolt threads.

To check bolts covered by Do-Nuts, try to rotate them. If the Do-Nut rotates, then the bolt it covers should be tightened (See image 1).

To access the bolt, the Do-Nut cap needs to be removed. Remove the cap by gently tapping a screwdriver through the cap and pry the cap loose (See image 2).

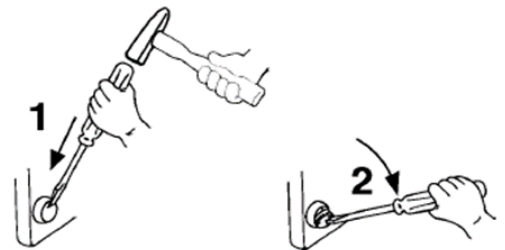

**⚠ WARNING! - Always use safety glasses when removing Do-Nut cap**

Be aware to use a tool on both screw and nut when tightening screws on your product:

Remember to check the drive rivet is intact. If rivet is loose or missing – install a new rivet.

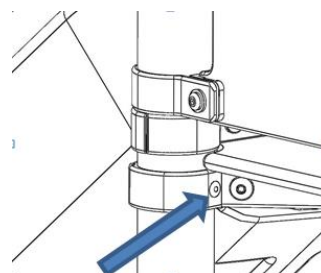
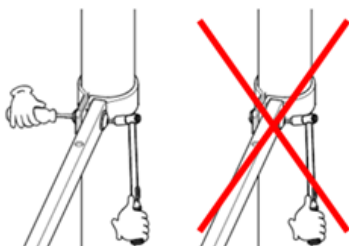

**IMPORTANT!** Inspection should always be done according to this instruction in combination with the installation instructions for the product. Remember that there might be a specific instruction for the product line as well.

# Work Sheet 1

## GENERAL

| Area                    | Inspection   | Maintenance  | 1 | 2 | 3 | 4 |
|-------------------------|--|--|---|---|---|---|
| Cleanliness             |  | Remove soil, leaves and debris on or around equipment.   | X | X | X |   |
| Broken or missing parts | Check for broken, loose or missing parts.  | Replace or tighten if necessary.   | X | X | X |   |
| Covers                  | Check for missing covers   | Replace if necessary   |   | X | X |   |
| Added parts             | Check for items tied or added to products (ropes, clothing etc.)                                     | Remove   | X | X | X |   |
| Connections             | Check all bolt connections are tight. Check rivets are not loose or broken.                          | Tighten connections or replace with new hardware if necessary. Use installation instructions for products with specified torque. You may have to remove bolt covers – if damaged replace with new. |   | X | X |   |
|                         | Check for gaps around slides, fireman's poles, roofs or bannister bars where clothing may get caught | Re-tighten loose or dislocated items. If this is not enough a non-entanglement devise may be able to solve the issue. This can be supplied from your local KOMPAN representative.                  |   | X | X |   |
| Moving parts            | Check rotating or moving parts for function and wear.  | Replace if necessary.  |   | X | X |   |
|                         | Check protective covers are undamaged and in place.  | Replace if necessary.  |   | X | X |   |
|                         | <b>Examples of moving parts:</b>   |  |   |   |   |   |
|                         | Suspension elements  | Replace parts if worn more than 50%, if they show cracks or other sign of deterioration.   |   | X | X |   |
|                         | Bearings<br>Rotating items and swing suspensions.  | Replace parts if movement is partly or fully prevented or unsmooth.  |   | X | X |   |
|                         | Springs and rubber elements:   | Tighten connections if necessary. Replace or repair in case of corrosion.  |   | X | X |   |
|                         | Rotating rings e.g. Supernova  | Replace parts if movement is partly or fully prevented or unsmooth.<br><br>Re-install or replace if rubber gasket is loose or missing.   |   | X | X |   |

- 1 Visual Routine Inspection, Daily to Weekly
- 2 Operational Inspection, Every 1 to 3 months
- 3 Main Inspection, Annual or half year
- 4 Additional to main inspection, 5 year



# Work Sheet 2

## GENERAL

| Area                   | Inspection   | Maintenance  | 1 | 2 | 3 | 4 |
|------------------------|--|--|---|---|---|---|
| Ropes                  | Inspect rope parts for wear.   | Steel wire may be visible but when steel wire starts to fray the rope must be replaced.          |   | X | X |   |
| Chains                 | Check chains for damage or wear.   | When worn more than 50% they must be replaced.   |   | X | X |   |
| Cables for Cableways   | Check cables for wear damage or corrosion.   | If cable starts to fray or show signs of damage it must be replaced.                             |   | X | X |   |
|                        | Check tension  | Adjust according to installation instruction if necessary.                                       |   |   | X |   |
| Plastic and rubber     | Check plastic and rubber parts for wear, damage or cracks  | Replace if necessary.  |   | X | X |   |
| Plywood panels         | Check plywood panels for excessive wear and deterioration  | Replace or repair if necessary.  |   | X | X |   |
| HPL Panels             | Check for excessive wear and sharp edges due to vandalism or other damages   | Replace if necessary.  |   | X | X |   |
| Metal parts in general | Check for sharp edges.<br>Check welds for fractures or separations   | Repair or replace if necessary.  |   | X | X |   |
| Painted steel          | Check for scratches, wear and initial corrosion.   | Repair paint by removing all corrosion and add a proper coating or replace parts if necessary.   |   | X | X |   |
| Galvanized             | Check for scratches, wear and initial corrosion.<br>Small scratches will repair themselves – larger damages may result in corrosion if not repaired. | Repair galvanizing by removing all corrosion and add a zinc spray or replace parts if necessary. |   |   | X |   |
| Aluminum               | Check for damage or wear.  | Replace if necessary.  |   | X | X |   |
| Electronics (ICON)     | Inspection must be carried out by ICON professional according to ICON Maintenance Instruction.   | Maintenance must be carried out by ICON professional according to ICON Maintenance Instruction.  |   | X | X |   |

- ① Visual Routine Inspection, Daily to Weekly
- ② Operational Inspection, Every 1 to 3 months
- ③ Main Inspection, Annual or half year
- ④ Additional to main inspection, 5 year

# Work Sheet 3

## FOUNDATIONS

| Area        | Inspection   | Maintenance                                   | 1 | 2 | 3 | 4 |
|-------------|--|---|---|---|---|---|
| Foundations | Check all foundations are stable and sharp edges and concrete is covered by surfacing. | Stabilize foundation and reinstate surfacing. |   | X | X |   |

## PRODUCTS RELYING ON ONE POST ONLY

| Area   | Inspection   | Maintenance  | 1 | 2 | 3 | 4 |
|--|--|--|---|---|---|---|
| Remove surfacing to inspect the conditions of the post where concreted in.   |  |  |   |   |   |   |
| Galvanized posts.  | Check if zinc layer is complete and there are no visual indications of corrosion to steel – rust.<br>Minor scratches<br>Major corrosion weakening the post | In case of minor scratches repair by use of spray zinc.<br>In case of corrosion weakening the post – replace the post. |   |   |   | X |
| Robinia Posts  | Check by use of pointed tool like an awl or small screwdriver if the wood is deteriorating.  | Replace post when more than 20% of the cross section is deteriorated   |   |   |   | X |
| If installed with wet pour rubber surfacing the rubber can be removed and re-instated by: <ul style="list-style-type: none"> <li>• Cut away the rubber around the post and glue the pieces back in after inspection.</li> <li>• Remove the rubber and re-instate with new material by use of the wet pour repair kit.</li> </ul> Note that only trained wet pour installers are supposed to do this. |  |  |   |   |   |   |

- ① Visual Routine Inspection, Daily to Weekly
- ② Operational Inspection, Every 1 to 3 months
- ③ Main Inspection, Annual or half year
- ④ Additional to main inspection, 5 year

# Work Sheet 4

## ROBINIA PRODUCTS

Robinia products are made from natural whole cut wood which must be expected to crack.

The design of the products takes cracks, imperfections and variable dimension within a specified range into consideration. Structural integrity will remain acceptable despite of even large cracks or imperfections.

For inspection and maintenance of Robinia products please perform the below tasks in addition to the general tasks:

| Area                  | Inspection   | Maintenance  | 1 | 2 | 3 | 4 |
|-----------------------|--|--|---|---|---|---|
| Checking and Cracking | Check if cracks have occurred.   |  |   |   |   |   |
|                       | Large cracks preventing bolts or other connections to be tightened.  | Take photos and seek guidance by your local distributor.   |   | X | X |   |
|                       | Cracks creating a non-compliance with safety standards.<br>E.g. Cracks near slides and other areas with forced movement. |  |   | X | X |   |
|                       | Minor cracks not affecting structural integrity or safety.   | Sand down edges to prevent splinters and sharp edges.<br>If visual appearance is diminished cracks can be repaired by use of our repair kit.<br>Ask your local distributor for advice. |   | X | X |   |
| Rot                   | Check by use of pointed tool like an awl or small screwdriver if the wood is deteriorating.                              |  |   |   |   |   |
|                       | Structural parts<br>If more than 30% of the cross section is deteriorated  | Post is to be replaced.<br>Contact your local distributor for advice.  |   | X | X |   |
|                       | Nonstructural parts and ends<br>If more than 30% of the cross section is deteriorated over a length of 100mm or more.    | Post can be replaced under warranty if requested.  |   | X | X |   |
| Knots                 | Loose knots  | Repair loose knots by use of repair kit.<br>Unrepaired knots may lead to rot which might not be covered if caused by a knot.   |   | X | X |   |
| Cleaning              |  | Remove dirt, algae or mold by use of power washer.   |   |   | X |   |
| Paint                 | Paint on Robinia is visual only  | We recommend touch up paint to maintain the appearance   |   |   | X |   |

- ① Visual Routine Inspection, Daily to Weekly
- ② Operational Inspection, Every 1 to 3 months
- ③ Main Inspection, Annual or half year
- ④ Additional to main inspection, 5 year

# Work Sheet 5

## SURFACING

| Area                   | Inspection   | Maintenance  | 1 | 2 | 3 | 4 |
|------------------------|--|--|---|---|---|---|
| Loose fill surfacing   | Check loose fill according to basic level marks on products.                                   | Reinstate if necessary. Special attention must be paid to heavily used areas like under swings and in the run-out area for slides. | X | X | X |   |
|                        | Check for unintended items in the loose fill surfacing or sand and gravel on rubber surfacing. | Remove if necessary  | X | X | X |   |
|                        | Check depth of loose fill according to: Table 4 of EN1176-1:2017 Table 3 of EN16630:2015.      | Reinstate if necessary   |   | X | X |   |
| Wet pour               | For more details see page 9  |  |   |   |   |   |
|                        | Cleaning   | Remove sand, gravel, debris and other unwanted items   | X | X | X |   |
|                        | Check for standing water   | Clean for improvement of porosity and drainage   | X | X | X |   |
|                        | Check for algae, moss weeds or fungus  | Remove by brush or power washer  |   | X | X |   |
|                        | Check joints between colors and shapes and surface around posts etc.                           | Repair if necessary. See instruction for repair work of wet pour   |   |   | X |   |
|                        | Check for damages and wear.  |  |   |   | X |   |
| Rubber tiles           | Check rubber tiles are even and do not present tripping hazards                                | Re-instate if necessary  |   |   | X |   |
|                        | Check maintenance instruction from supplier for further instructions                           |  |   |   | X |   |
| Grass mats             | If grass mats are regarded impact surfacing the holes must be kept free from sand or soil.     | Re-instate if necessary.   |   | X | X |   |
| Other impact materials | Check maintenance instruction from supplier for further instructions                           |  |   |   |   |   |

- ① Visual Routine Inspection, Daily to Weekly
- ② Operational Inspection, Every 1 to 3 months
- ③ Main Inspection, Annual or half year
- ④ Additional to main inspection, 5 year

# Work Sheet 6

## SIGNAGE

| Area               | Inspection  | Maintenance         | 1 | 2 | 3 |
|--------------------|---|---------------------|---|---|---|
| General:           | Check product marking, for information about product ID, manufacturer or distributor ID, reference to safety standard if required.  | Replace if missing. |   |   | X |
| Fitness equipment: | Check the site has a sign informing about: <ul style="list-style-type: none"> <li>• How to use equipment</li> <li>• Age or height limitations</li> <li>• Assurance about medical safety</li> <li>• Emergency phone number</li> <li>• Contact info for maintenance</li> <li>• Address of facility</li> </ul> | Replace if missing. |   |   | X |

- ① Visual Routine Inspection, Daily to Weekly
- ② Operational Inspection, Every 1 to 3 months
- ③ Main Inspection, Annual or half year